



HILLSIDE TOTE

a simple yet organized crossbody tote

noodlehead

HILLSIDE TOTE

Perfect for on the go when you want something a little simpler but still keep organized. This classic crossbody with a zip top closure will be one you will want to make over and over again. Feature your favorite print or keep it simple with a solid! Includes front and back exterior pockets and interior pocket. Adjustable strap makes it wearable in any season. Perfect for gifting! Regular size and mini!

Approx. Finished Dimensions: 9 1/2" wide by 3" deep (measured at base), 9 1/4" tall, width at top opening is 12 1/2" [8 1/4" wide by 2 1/2" deep (measured at base), 8 1/4" tall, width at top opening is 10 1/2"]

Supplies:

- Requirements based on 44"-wide fabric
- Exterior fabric requirement not suitable for one-way directional fabric.
- **Mini size noted in [brackets].**
- FQ=Fat Quarter (18" x 22")

Exterior Fabric	1/2 yard [FQ]
Accent Fabric (includes Exterior pockets and Strap/Strap Holders)	1/2 [1/2] yard
Lining Fabric (includes Interior Pocket)	3/4 [1/2] yard
Fusible Woven Interfacing (Pellon SF101 - 20"-wide) [^]	2 1/4 [1 7/8] yards
(1) 12" [10"] zipper for top closure	
(2) 1"-wide d-rings, (2) 1"-wide swivel clasps AND (1) 1"-wide strap slider	
(1) 18mm thin magnetic snap (for front pocket closure) OR (1) size 24 metal snap can be substituted	
Recommended Fabrics: Canvas (6-8 oz. weight) for exterior and Accent fabric. Quilting cotton or lightweight canvas for Lining.	
[^] = depending on your exterior or accent fabric choice (such as a heavier canvas or a waxed canvas in a 7-9 oz. weight), you may be able to omit the interfacing for the exterior fabric and/or some of the accent pieces. For this option, reduce fusible interfacing requirement to 1 1/4 [3/4] yards and do not interface those pieces.	
Additional supplies + tools: Polyester thread, water-soluble pen/tailor's chalk, cutting mat, ruler, rotary cutter, size 14 or 16 denim or Microtex needle, glue or glue pen, (optional) 1"-wide x 50" leather strap/webbing may be substituted for fabric strap	

Want a single fabric exterior? Cut the Exterior pockets, Strap, and Strap Holders, Zipper End Tab, and Main Panel all from the same fabric. You will need 3/4 yard and can omit the Accent Fabric requirement. See cutting layout on page 4 of this PDF.

Want to skip the interfacing on the lining, too? I love taking short cuts and have been very happy with the results of using a cotton canvas for the lining fabric requirement. My favorite is Big Sur Canvas (9.6 oz. weight) by Robert Kaufman (ask your local quilt shop if they carry it!).

Featured Fabrics are Surface by Amy van Luijk for Figo Fabrics.

Pattern Information:

Please read through all instructions before beginning.

- 1/2" seam allowance throughout, unless otherwise noted
- 1/4" seam allowance for basting (4-5.0mm stitch length), unless otherwise noted
- Make sure to backstitch at beginning and end of each seam to secure stitches.
- Topstitch 1/8" away from edges or seams
- Use a longer stitch length when topstitching (2.8-3.0mm)
- RST=right sides together, WST=wrong sides together

Sell finished sewn items: You (the purchaser) may sell finished sewn items. Includes home-based production scale only. No commercial production allowed.

Pattern may NOT be reproduced, shared or redistributed.



Cutting Tips:

- Please note that ALL pattern pieces are rectangular (with measurements given below). For best accuracy, use a gridded ruler, rotary cutter, and cutting mat to cut the rectangular pieces to size.
- **Time saving tip!** Once you've cut the pieces from your Exterior/Accent/Lining fabrics, use them to cut your interfacing. Lay the fabric pieces on top of your interfacing and trim the interfacing to size.
- It may be helpful to label all pieces to avoid any confusion during construction (printable label page is on page 11).
- **Seam allowances are included in all measurements and pattern pieces.**

Cutting Instructions:

From **Exterior Fabric:**

- (1) 23" tall x 14" wide [19 1/2" tall x 12" wide] Main Panel
- (1) 1 1/4" tall x 2" wide Zipper End Tab

From **Accent Fabric:**

- (2) 8 1/2" tall x 14" wide [7 1/2" tall x 12" wide] Exterior Pocket**
- (2) 4" tall x 28" wide Strap**
- (2) 2" tall x 4" wide Strap Holder**

From **Lining Fabric:**

- (2) 12" tall x 14" wide [10 1/4" tall x 12" wide] Lining Main
- (2) 8 1/2" tall x 14" wide [7 1/2" tall x 12" wide] Exterior Pocket
- (2) 8" tall x 14" wide [7" tall x 12" wide] Interior Pocket

From **Fusible Woven Interfacing:**

- (1) 23" tall x 14" wide [19 1/2" tall x 12" wide] Main Panel
- (2) 8 1/2" tall x 14" wide [7 1/2" tall x 12" wide] Exterior Pocket**
- (1) 4" tall x 51" wide Strap**
- (2) 1" tall x 4" wide Strap Holder**
- (2) 12" tall x 14" wide [10 1/4" tall x 12" wide] Lining Main
- (1) 8" tall x 14" wide [7" tall x 12" wide] Interior Pocket

**= depending on your accent fabric choice, you may choose to omit the fusible woven interfacing from the indicated pieces.

Suggested Cutting Layouts:

- These are cutting suggestions, change to suit your needs as desired.

Exterior Fabric [all sizes]:

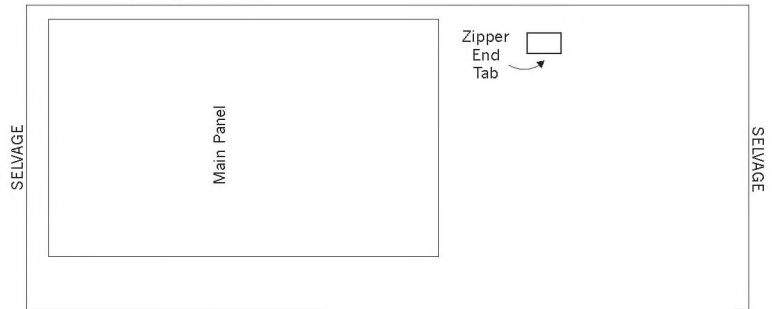

Accent Fabric [all sizes]:

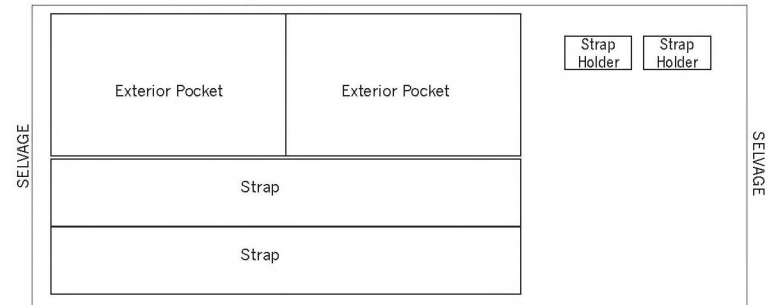

Lining Fabric:

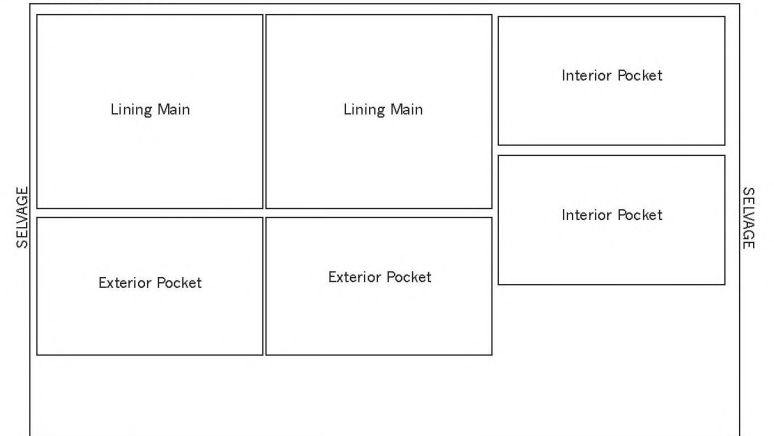

Lining Fabric [MINI]:

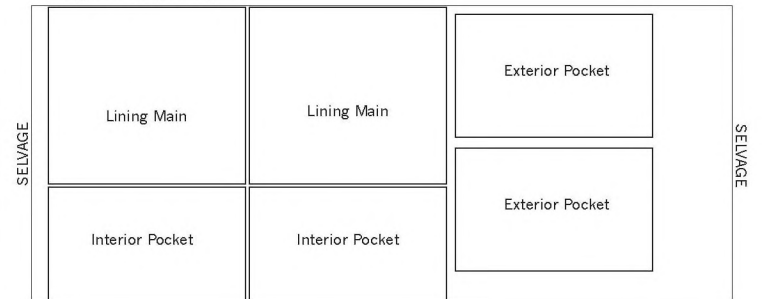

Fusible Woven Interfacing [MINI]:

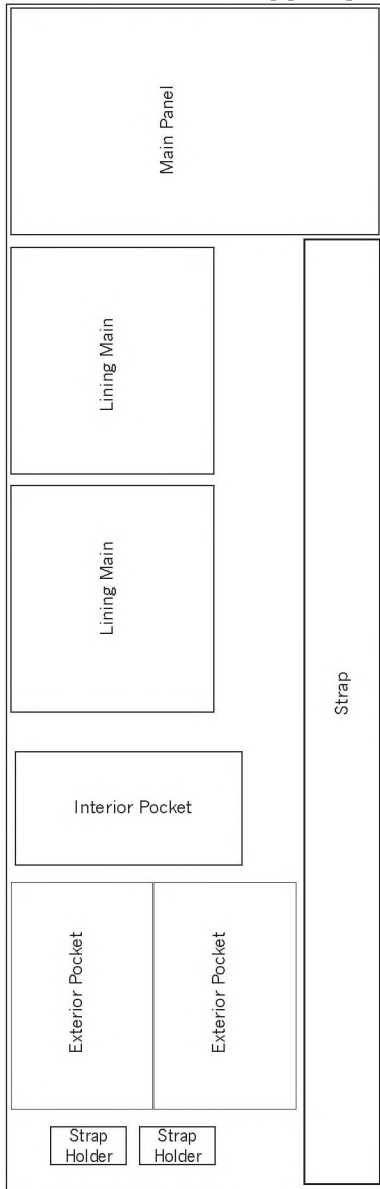

Fusible Woven Interfacing:

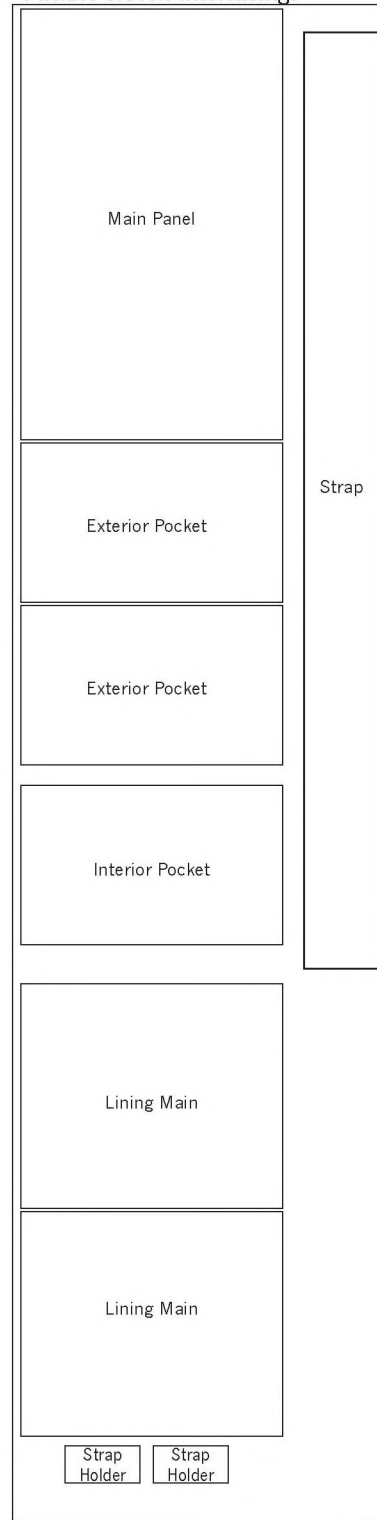

Exterior Fabric (from single fabric, all sizes):

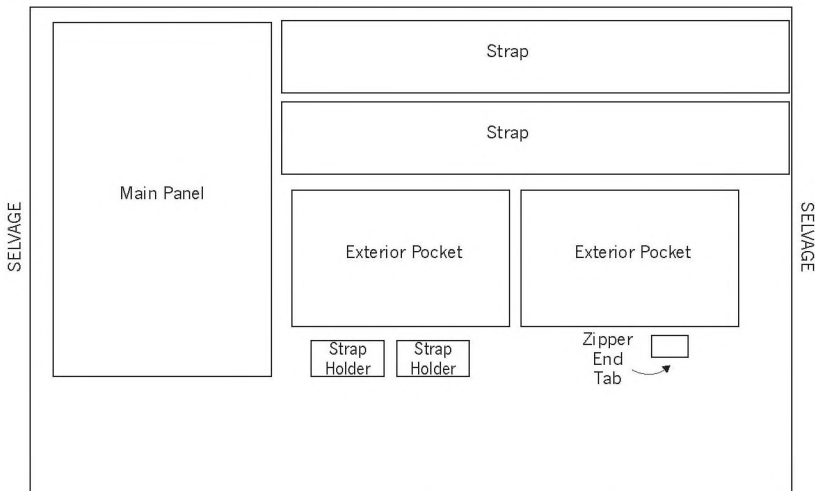

SEWING INSTRUCTIONS:

RST = Right Sides Together
WST = Wrong Sides Together



1/2" SEAM ALLOWANCE USED THROUGHOUT UNLESS OTHERWISE NOTED.

MAGNETIC SNAP:

Follow my Magnetic Snap Tutorial for step-by-step photos and extra tips for a successful installation:

www.noodle-head.com/2013/05/magnetic-snap-tutorial.html

SNAP INSTALLATION:

For more tips and information on installing metal snaps: www.noodle-head.com/2015/02/snap-tutorial.html

PREPARE: APPLY INTERFACING

1. Fuse woven interfacing to the wrong side of each corresponding **exterior** piece: Main Panel.
2. Fuse woven interfacing to the wrong side of each corresponding **accent** piece: Exterior Pocket, Strap Holders (as shown). Strap interfacing will be fused in a later step.

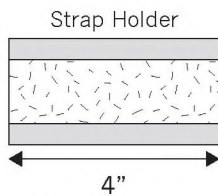

3. Fuse woven interfacing to the wrong side of the corresponding **lining** pieces: Lining Main, one Interior Pocket.

STEP 1: MAKE STRAP HOLDER

- a. Fold Strap Holder in half WST, matching 2" sides. Open and press raw edges to center crease. Fold in half again and press. Strap Holder will be 1" by 2".

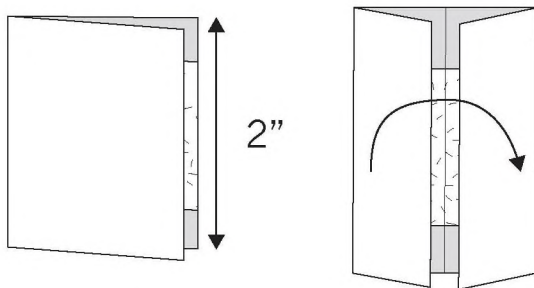

- b. Topstitch along both 2" sides of Strap Holder. Add additional rows of topstitching as desired.
- c. Repeat Step 1a-b for remaining Strap Holder.

- d. Thread Strap Holder through d-ring. Fold Strap Holder in half with raw edges aligned. Baste ends together. Repeat for remaining Strap Holder/d-ring and set both aside.

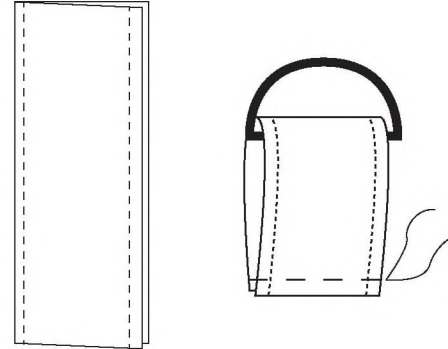

STEP 2: MAKE STRAP

- a. Place two short ends of Strap pieces RST perpendicular to each other and pin. Sew a line diagonally from corner to corner as shown. Trim seam allowance to 1/4". Press seam open. Fuse interfacing to the wrong side of the sewn strap as shown. Press both short ends to the wrong side by 1/2".

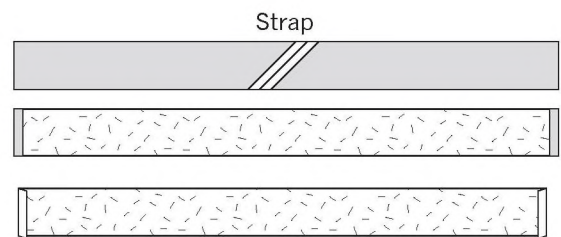
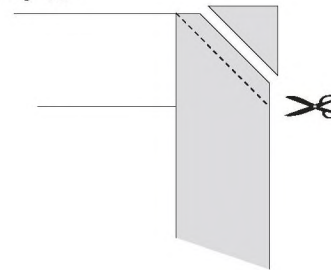

- b. Fold Strap in half lengthwise WST. Open and press raw edges to center crease. Fold in half again and press (being sure to neatly tuck in any exposed raw edges). Strap will be 50" long by 1" wide.
- c. Topstitch along both long edges. Add additional rows of topstitching as desired. Set aside.

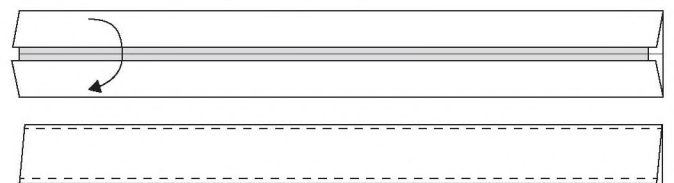

STEP 3: ASSEMBLE EXTERIOR

- Fold Main Panel (exterior fabric) in half RST matching 14" [12"] edges.
- Using a clear ruler mark a rectangle 1 1/2" [1 1/4"] wide by 1" [3/4"] tall in each corner at the bottom fold. Cut out each corner along marked rectangle.

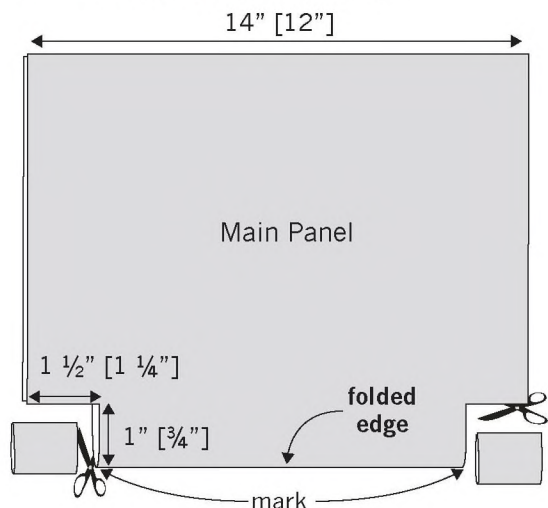

- With chalk or a water-soluble pen, mark a line within the seam allowance at the bottom fold on both sides of the Main Panel. Unfold exterior and set aside.
- Place two Exterior Pocket pieces (one from Accent fabric, one from Lining fabric) RST. Pin then sew along both 14" [12"] edges. Press seams open. Turn right side out and press.

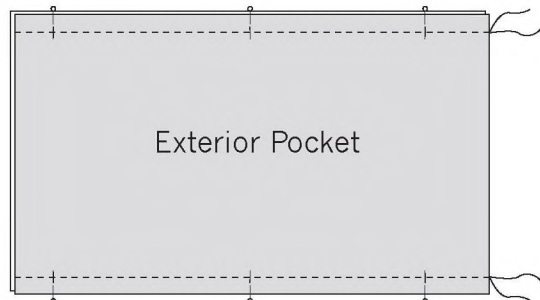

- Topstitch along one 14" [12"] edge. Add additional topstitching 1/4" below previous topstitching.



- Repeat Step 3d-e for remaining Exterior Pocket pieces. Set one pocket aside.
- (If using magnetic snap, skip to next step). For metal snap, install cap half of snap centered on one Exterior Pocket (5/8" from top edge) through both layers. *You will be installing the remaining half of snap in a later step.* SKIP TO STEP 3m.

- Centered on one Exterior Pocket lining, measure 3/4" down from top raw edge and make a mark.

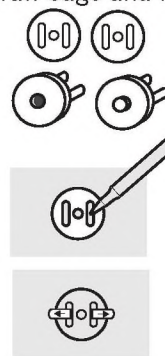

TIP: If using waxed canvas, use a non-fusible interfacing/stabilizer for installing the magnetic snap.

- Use a water-soluble pen to mark where the prongs of the magnetic snap will be using the washer as a guide. On wrong side of lining (reaching in between the fabric layers), fuse small scrap of fusible interfacing over marking.
- Cut small slits into the lining piece where you marked the prong placement. You can also add a dab of seam sealant to stop any future fraying of the fabric.
- From the right side of the lining, push the prongs of the snap through fabric. Take a small piece of batting or stiff interfacing, cut slits, and slip over prongs. Slip washer over prongs. Bend prongs over to sides.
- Fuse additional scrap of fusible interfacing over entire back of snap. *You will be installing the remaining half of snap in a later step.*
- With Main Panel right side facing up, center completed Exterior Pocket (lining side down) on top. Top edge of pocket will be 2 1/4" [1 3/4"] from top 14" [12"] edge of Main Panel. Pin and baste in place along each side.
- Topstitch along bottom edge of pocket.

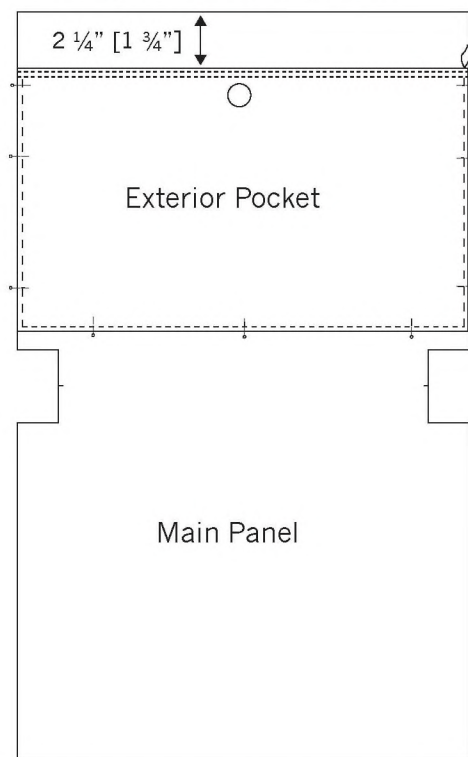

- Repeat Step 3m-n for remaining Exterior Pocket, this time attaching pocket to opposite side of Main Panel.

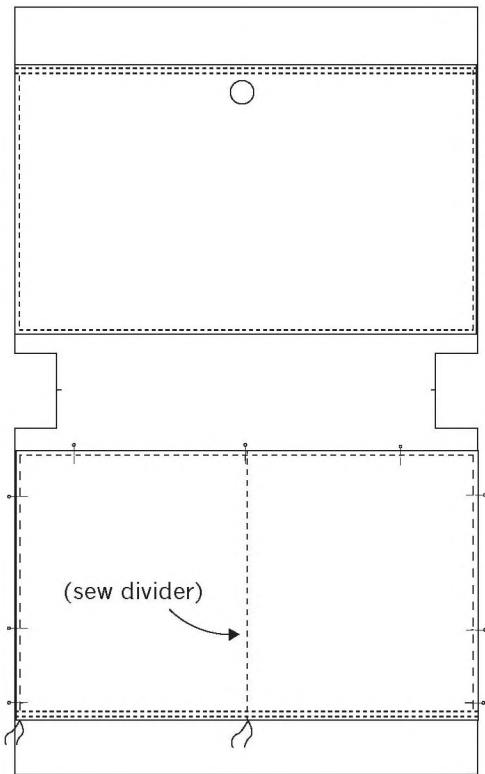

- p. Mark a vertical line centered on back pocket.
- q. Sew on the marked divider line from bottom of pocket to top, being sure to backstitch at both ends. The pocket will now be divided in two.
- r. **If using a magnetic snap**, repeat Steps 3i-l to install the remaining half of magnetic snap, attaching it to the Main Panel exterior piece using the installed half of the snap from pocket to mark the matching location. **Skip to STEP 3t.**
- s. **If using a metal snap**, install remaining half of metal snap on Main Panel exterior piece using the previously installed cap half of the snap to mark the matching location. Proceed to next step.
- t. Baste the Strap Holders in place with the bottom edge of Strap Holder aligned to top edge of front pocket. D-rings will face toward the center of the front exterior. The exterior is now complete, set aside.

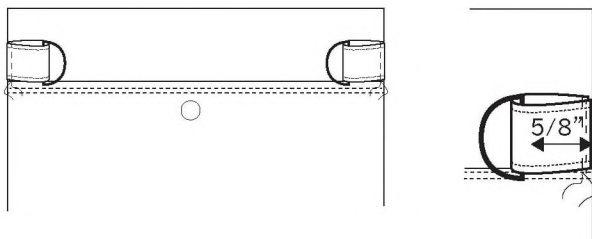

TIP: Make sure that there is approximately $\frac{5}{8}$ " of space from the d-ring to the side of the Back Panel for each Strap Holder. This will ensure you won't hit the d-rings while sewing each side seam later on. It may help to switch to a narrow foot.

STEP 4: ASSEMBLE LINING

- a. Make interior pocket by placing Interior Pocket pieces RST. Pin then sew along both long 14" [12] edges. Press seams open. Turn right side out and press.
- b. Topstitch along one long edge of Interior Pocket. Add additional topstitching $\frac{1}{4}$ " below previous topstitching. This will be the top edge of the pocket.

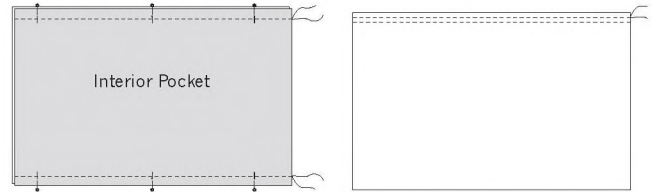

- c. Place top edge of pocket $2\frac{3}{4}$ " [$2\frac{1}{4}$ "] from top 14" [12"] edge of one Lining Main piece, aligning sides to edges of Lining Main. Pin in place on sides and bottom edge of pocket.
- d. Baste sides of pocket to Lining Main. Topstitch along bottom edge of pocket.
- e. Mark pocket divider by finding vertical center of pocket.
- f. Sew on the marked divider line from bottom of pocket to top, being sure to backstitch at both ends. Set aside.

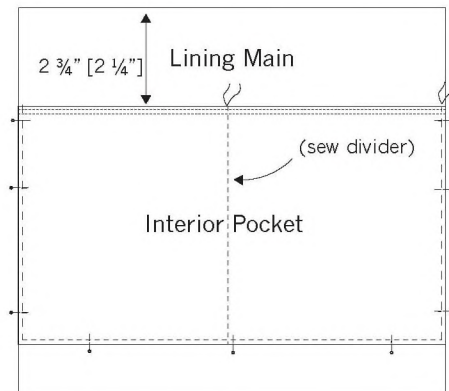

STEP 5: PREPARE ZIPPER

- a. Fold the end tab in half widthwise (matching $1\frac{1}{4}$ " edges) WST and press, fold each short end WST to center crease and press. Fold in half again and press. End Tab will measure $1\frac{1}{4}$ " x $\frac{1}{2}$ ".

TIP: Depending on your zipper type (plastic/metal) and brand, it may be necessary to trim the zipper tape end before applying end tab. Trim zipper tape so that it extends $\frac{1}{2}$ " past the metal end bottom-stop.

- b. Sandwich the end tab around the zipper end, just avoiding the metal end bottom-stop.

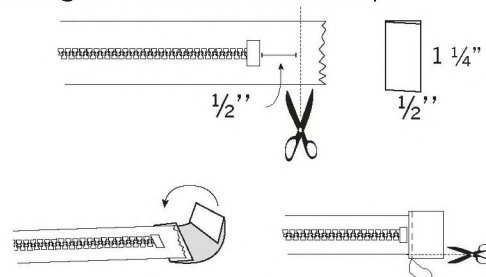

- c. Using your zipper foot, topstitch a line straight across the zipper end tab being careful not to hit the metal end stop. Trim the fabric tab to the width of the zipper.

- d. Bend pull-side zipper tape ends back on themselves and machine or hand stitch in place.

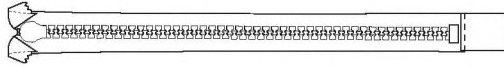
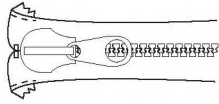

STEP 6: INSERT TOP ZIPPER CLOSURE

If you prefer your zipper to open from the opposite direction, when the instructions for zipper pull placement say RIGHT, place LEFT and so on.

- Place the front tote exterior (pocket with snap) RIGHT side up. Center the zipper (right side down) with zipper pull to the RIGHT. Zipper End Tab will be approximately $\frac{3}{4}$ " from the left edge of the tote. Baste (or glue) in place.
- Place lining piece (without pocket) RIGHT SIDE DOWN on top, 14" [12"] edge aligned to zipper tape. Pin or glue in place.

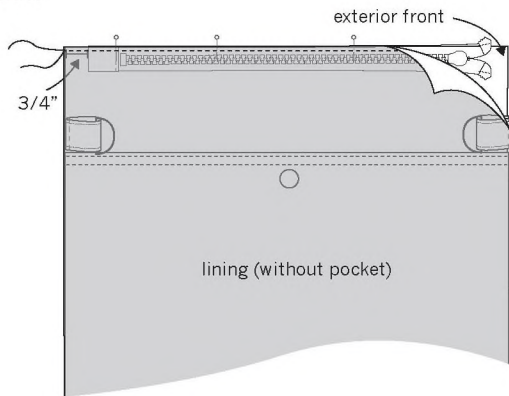

- Using your zipper foot, sew along the edge of the 'zipper sandwich' using a $\frac{1}{4}$ " seam allowance.

- Press **exterior** piece away from zipper.
- Topstitch along zipper **through exterior fabric and the seam allowance only, keeping the Lining Main piece out of the way.**

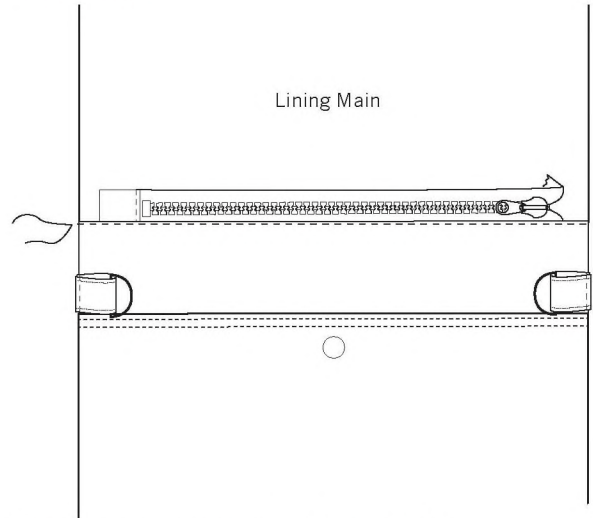

- Press all layers away from zipper, WST.
- Place the tote so the exterior back (with divided pocket) is right side up on your work surface. Pocket opening will be facing away from you.
- Bring the remaining zipper tape edge (the zipper will now have the front and one lining piece attached) up to meet the top edge of the exterior back. The zipper will be right side down with zipper pull on the LEFT this time. Baste in place.

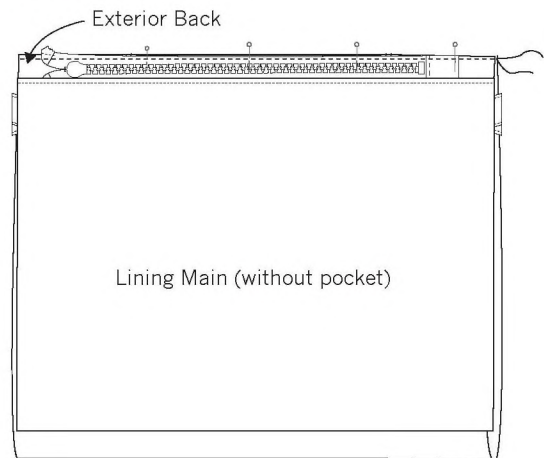

- i. Place the remaining lining piece (WITH pocket) RIGHT SIDE DOWN on top of the zipper. The pocket **opening** will be facing up toward the zipper. Pin in place (or glue), sew using a $\frac{1}{4}$ " seam allowance.

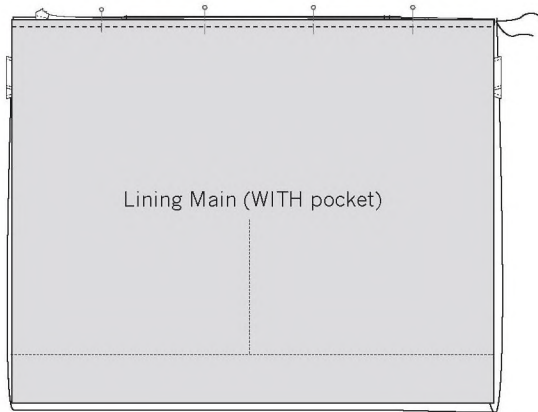

- j. Open zipper completely. Press exterior fabric away from zipper.
 k. Topstitch on remaining side of the zipper **through exterior fabric and the seam allowance. Be sure to keep Lining Main piece (with pocket) out of the way.**

TIP: You'll be sewing with the zipper connected. Go slow and start from the open zipper end, moving the front exterior and lining fabric out of the way as you go. It'll be a little trickier with the mini tote, but you can do it!

- l. Press all layers away from zipper, WST.
 m. Close the zipper halfway. This will help to keep everything in alignment.
 n. Place exterior pieces RST and lining pieces RST, separately (see diagram, Step 6p for overall visual). Pin. Make sure to bend the zipper end tab and teeth in toward the lining and align top edge of front/back pocket on each side seam.

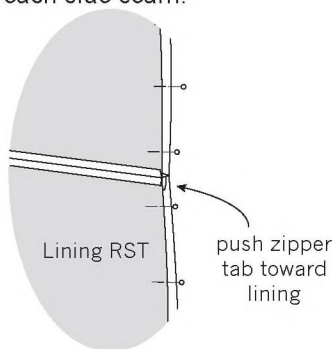

- o. With a water-soluble pen mark a $1\frac{1}{2}$ " [$1\frac{1}{4}$ "] square in each corner of the both the lining corners. Cut out marked squares through all layers.

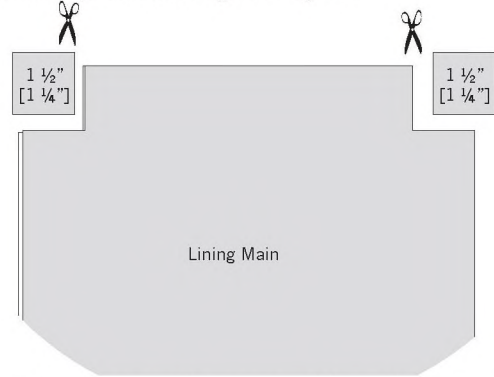

- p. Sew tote exterior side seams, lining side seams and bottom seam, leaving a 6-7" opening in the bottom seam of the lining for turning. Reinforce where Strap Holders are inserted into the side seam by sewing another line of stitching about $\frac{1}{4}$ " from the previous stitching.

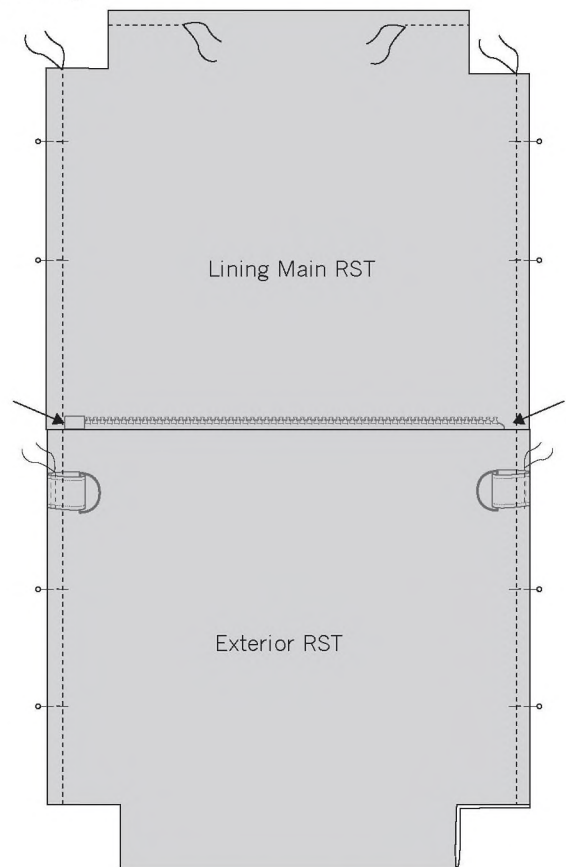

TIP: When sewing around the perimeter of the tote next to where the zipper is sewn in, you'll be sewing about $\frac{1}{4}$ " away from the zipper end tab, and not through it. You won't be able to see the end tab or zipper because the tote is being sewn inside out, but feel around the zipper end tab area before you sew across (see diagram). A zipper foot may be helpful. You will be sewing approximately $\frac{1}{4}$ " from metal zipper end stops pictured at right side of tote. Keep a steady $\frac{1}{2}$ " seam allowance and you'll do great!

TIP: To help the lining fit smoothly inside tote when finished, sew the lining pieces with a slightly larger seam allowance ($\frac{5}{8}$ " seam allowance instead of $\frac{1}{2}$ ").

- q. Trim seam allowance on tote lining to $\frac{1}{4}$ " except at opening (leave that $\frac{1}{2}$ "). Press seam opening in lining open.
- r. Press side seams open.
- s. To sew each corner seam (there are two exterior and two lining corners), reach inside tote and pinch the cut-out square together, fabrics RST. For the exterior corners, align bottom fold marking to match its corresponding side seam. Pin. Sew. Trim seam allowance to $\frac{1}{4}$ ". For the lining corners, align the bottom seam to match its corresponding side seam. Pin. Sew. Trim seam allowance to $\frac{1}{4}$ ".

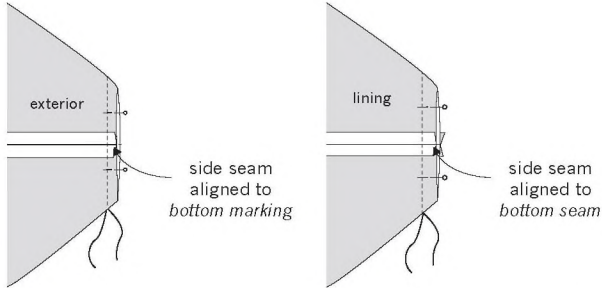

- t. Turn the tote right side out through opening in lining. Push out corners. I like to use my finger to really get in between the exterior and lining and push that zipper end tab out, it'll be nice and crisp!

TIP: Now is a good time to double check your sewing before closing the opening in the lining in the next step.

- u. Tuck in the raw edges of the lining opening. Sew the opening closed using a small seam allowance or by hand using a hidden stitch. Push the lining into the tote.
- v. Loop scrap of leather or ribbon through zipper pull.
- w. Press again.

STEP 7: ATTACH CROSSBODY STRAP

- a. Thread one strap end through strap slider center bar, folding back on itself. Sew in place 2" from strap slider by sewing a rectangle for reinforcement.

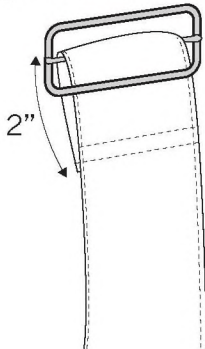

- b. Thread remaining strap end through one swivel snap end (1), up and over center bar of strap slider (2), down through the other swivel snap end (3) and up into place by about 2", folding back on itself (4). Sew in place by sewing a rectangle for reinforcement.

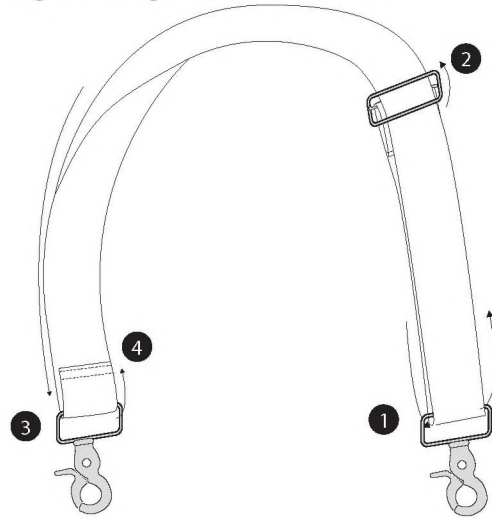

Connect your Strap to the d-rings and your tote is ready!

Share it on social media!
#HillsideTote #noodleheadpatterns



HILLSIDE TOTE: PRINTABLE LABELS

Keep track of the pieces as you cut! Print and cut out these labels to pin to your fabric as you cut. Please see cutting layouts and notes on pages 3-4 of this PDF.

For Regular size:

<p>HILLSIDE TOTE</p> <p>Main Panel</p> <p>23" tall x 14" wide</p> <p><input type="checkbox"/> (1) Exterior Fabric</p> <p><input type="checkbox"/> (1) Fusible Woven Interfacing</p>	<p>HILLSIDE TOTE</p> <p>Exterior Pocket</p> <p>8 1/2" tall x 14" wide</p> <p><input type="checkbox"/> (2) Accent Fabric</p> <p><input type="checkbox"/> (2) Lining Fabric</p> <p><input type="checkbox"/> (2) Fusible Woven Interfacing</p>	<p>HILLSIDE TOTE</p> <p>Strap</p> <p>4" tall x 28" wide</p> <p><input type="checkbox"/> (2) Accent Fabric</p> <p><input type="checkbox"/> (1) Fusible Woven Interfacing - 4" x 51"</p>	<p>HILLSIDE TOTE</p> <p>Strap Holder</p> <p>2" tall x 4" wide</p> <p><input type="checkbox"/> (2) Accent Fabric</p> <p><input type="checkbox"/> (2) Fusible Woven Interfacing - cut to 1" tall</p>
<p>HILLSIDE TOTE</p> <p>Zipper End Tab</p> <p>1 1/4" tall x 2" wide</p> <p><input type="checkbox"/> (1) Exterior Fabric</p>	<p>HILLSIDE TOTE</p> <p>Lining Main</p> <p>12" tall x 14" wide</p> <p><input type="checkbox"/> (2) Lining Fabric</p> <p><input type="checkbox"/> (2) Fusible Woven Interfacing</p>	<p>HILLSIDE TOTE</p> <p>Interior Pocket</p> <p>8" tall x 14" wide</p> <p><input type="checkbox"/> (2) Lining Fabric</p> <p><input type="checkbox"/> (1) Fusible Woven Interfacing</p>	

For Mini size:

<p>HILLSIDE TOTE MINI</p> <p>Main Panel</p> <p>19 1/2" tall x 12" wide</p> <p><input type="checkbox"/> (1) Exterior Fabric</p> <p><input type="checkbox"/> (1) Fusible Woven Interfacing</p>	<p>HILLSIDE TOTE MINI</p> <p>Exterior Pocket</p> <p>7 1/2" tall x 12" wide</p> <p><input type="checkbox"/> (2) Accent Fabric</p> <p><input type="checkbox"/> (2) Lining Fabric</p> <p><input type="checkbox"/> (2) Fusible Woven Interfacing</p>	<p>HILLSIDE TOTE MINI</p> <p>Strap</p> <p>4" tall x 28" wide</p> <p><input type="checkbox"/> (2) Accent Fabric</p> <p><input type="checkbox"/> (1) Fusible Woven Interfacing - 4" x 51"</p>	<p>HILLSIDE TOTE MINI</p> <p>Strap Holder</p> <p>2" tall x 4" wide</p> <p><input type="checkbox"/> (2) Accent Fabric</p> <p><input type="checkbox"/> (2) Fusible Woven Interfacing - cut to 1" tall</p>
<p>HILLSIDE TOTE MINI</p> <p>Zipper End Tab</p> <p>1 1/4" tall x 2" wide</p> <p><input type="checkbox"/> (1) Exterior Fabric</p>	<p>HILLSIDE TOTE MINI</p> <p>Lining Main</p> <p>10 1/4" tall x 12" wide</p> <p><input type="checkbox"/> (2) Lining Fabric</p> <p><input type="checkbox"/> (2) Fusible Woven Interfacing</p>	<p>HILLSIDE TOTE MINI</p> <p>Interior Pocket</p> <p>7" tall x 12" wide</p> <p><input type="checkbox"/> (2) Lining Fabric</p> <p><input type="checkbox"/> (1) Fusible Woven Interfacing</p>	

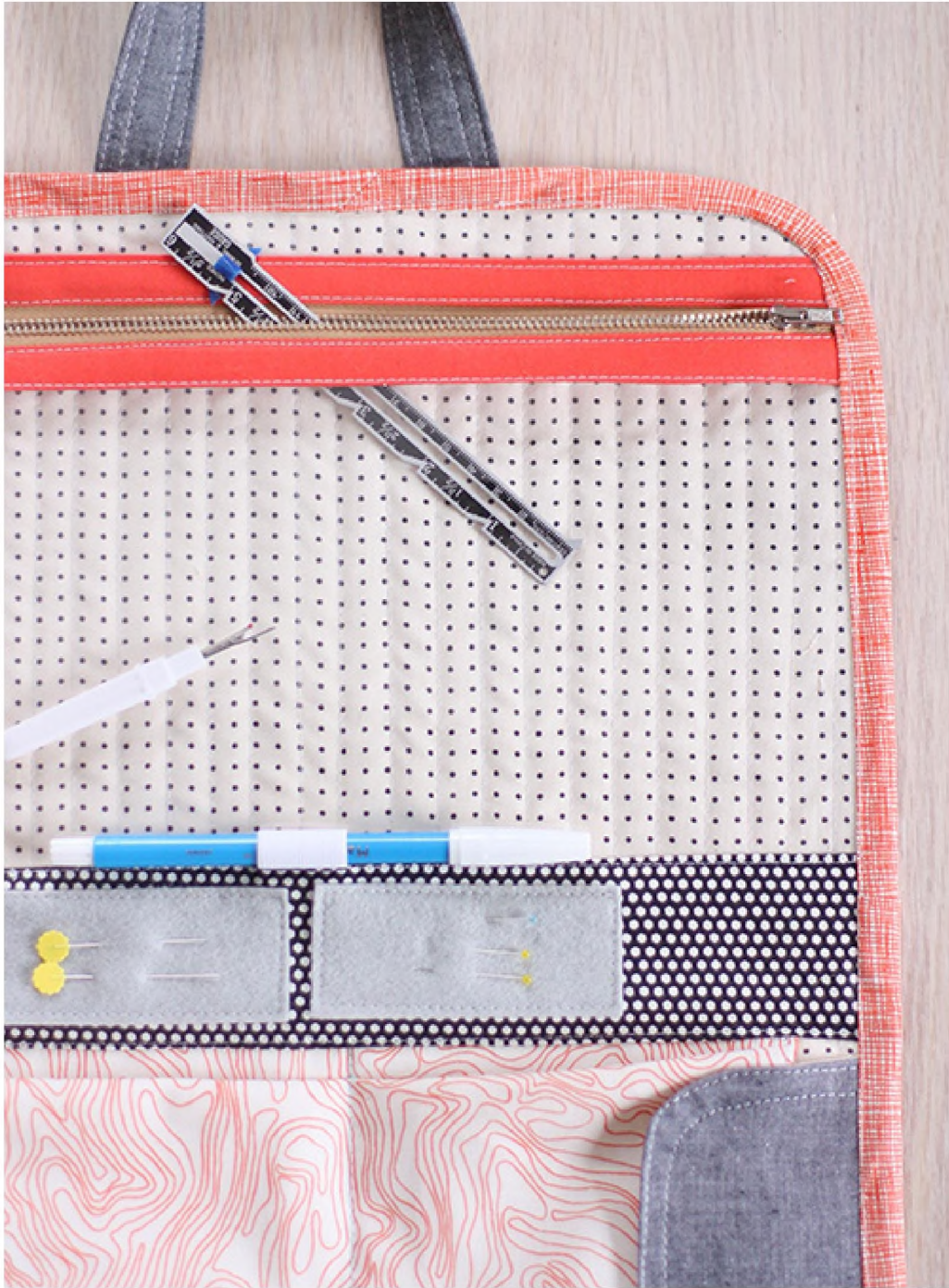

ROAD TRIP CASE

get organized | perfect for kids & crafts | 2 pocket configuration options

noodlehead

ROAD TRIP CASE

Great portable case for getting organized!

- Perfect for handwork, cross stitch, and embroidery project supplies
- Two pocket configurations: long pockets hold a rubber band loom, alternate configuration is great for kids' artwork supplies or sewing supplies!

Finished Dimensions:

13.5" wide, 9" tall (12.5" including handles), 18" tall when fully opened

Supplies:

+ FQ = Fat quarter = 18" x 22"

+ Additional fabric required if working with a directional print.

Main Exterior*	FQ
Main Lining*	FQ
Interior Pockets	FQ
Interior Accents	FQ
Cotton Canvas (used as stabilizer)	13.5" x 18"
Low Loft Cotton Batting or Fusible Fleece (Pellon 987F - 44" wide)	13.5" x 18"
16 Gauge Clear Vinyl	14" x 10"
12" Zipper	
Fusible Woven Interfacing (Pellon SF101 - 20" wide)	1/4 yard
1/2" Wide Double Fold Bias Tape	2 yards
Notions:	
<ul style="list-style-type: none"> • 2.5" piece of 1" wide elastic • 12" piece of 1/4" wide elastic (for long pocket version) • 1 button for flap pocket option, 3 for long pocket option • 3/4" wide hook & loop tape (for flap pocket option only) - 6" cut into (4) 1.5" wide pieces • 3 elastic hair ties (if not making fabric loops) 	
Suggested Fabrics: home dec, denim, canvas, twill, quilting cotton for exterior, quilting cottons for lining and accents.	
Additional tools + materials: thread, water soluble pen, cutting mat, ruler, rotary cutter, walking foot, binder clips, 1/4" wide fusible hem tape, size 14 sewing machine needle	

+ Please read through all instructions before beginning.

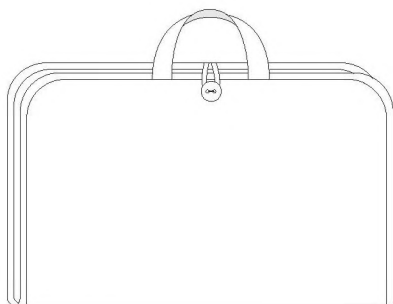

Pattern Information:

- 1/2" seam allowance throughout, unless noted
- 1/8" seam allowance for basting
- Make sure to backstitch at beginning and end of each seam to secure stitches.
- Topstitch 1/8" away from edges or seams
- Use a longer stitch length when topstitching (3.0mm) for even and smooth stitches
- To find center, finger press in half and mark within seam allowance

License to sell finished sewn items: By purchasing this pattern, the original purchaser has the rights to sell finished Road Trip Cases. License to sell includes home-based production scale only. No commercial production allowed.

Pattern may NOT be reproduced, shared or redistributed.

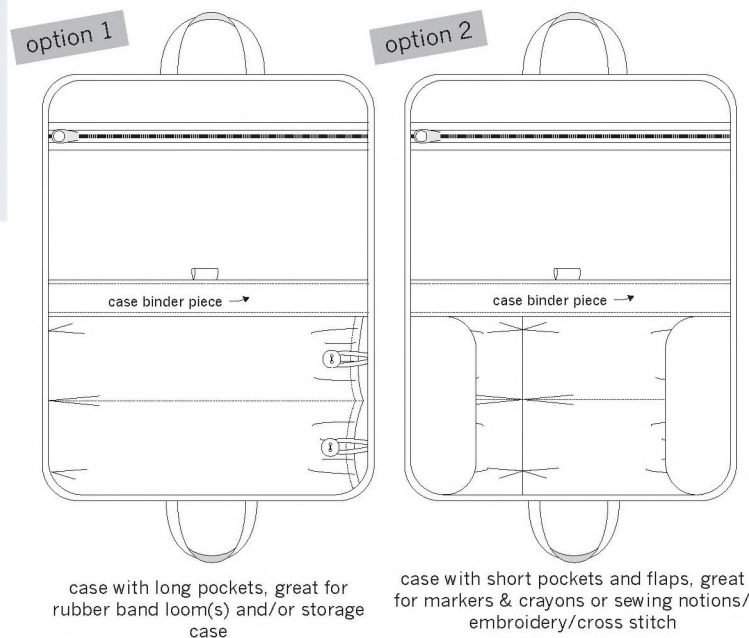

Assemble Pattern Pieces:

Print pattern piece and pleat template (pages 10-11) on your home printer. Be sure that your printer is NOT set to 'fit to page' when printing. Cut along solid lines, tape together at marked letters, matching 'A' to 'A' respectively and so on.

+ Seam allowances are included in all pattern pieces.

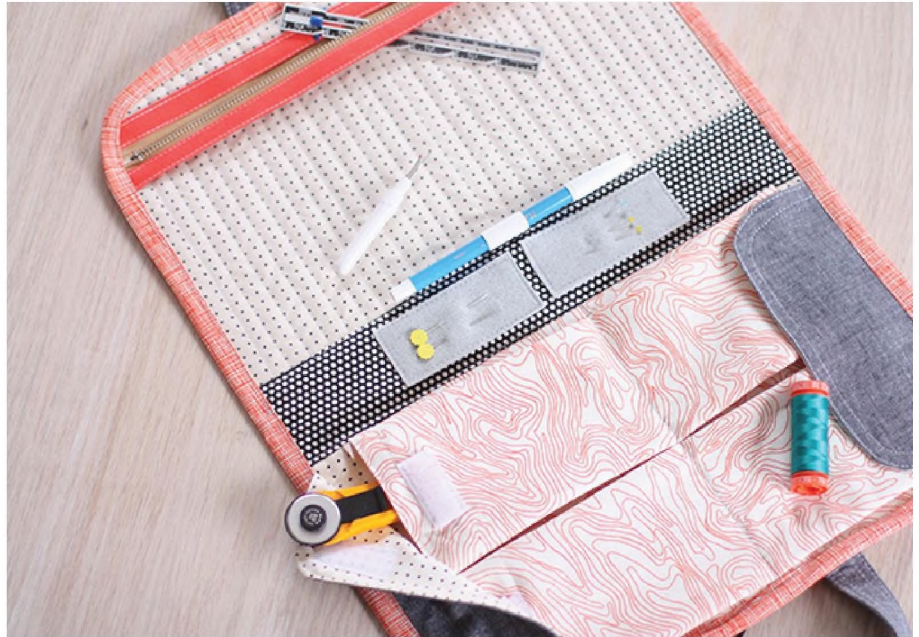

Cutting Instructions:

See suggested cutting layout on the next page.

From Exterior FQ:

(1) Exterior - 13.5" wide x 18" tall*

From Lining FQ:

(1) 13.5" wide x 18" tall*

(2) Handles - 11" wide x 4" tall

From Interior Pockets FQ:

(1) Interior Long Pockets - 13.25" wide x 12" tall

(3) Loops - 5" wide x 1.25" tall or use elastic hair ties

(2) Vinyl Pocket Binding - 13.5" wide x 2" tall

OR (for Alternate Pocket)

(1) Alternate Pocket Exterior - 12" wide x 12" tall

(2) Alternate Pocket Flap Exterior (use pattern piece)

(2) Vinyl Pocket Binding - 13.5" wide x 2" tall

From Interior Accent FQ:

(1) Interior Long Pockets Lining - 13.25" wide x 12" tall

(1) Case Binder piece - 13.5" wide x 3" tall

OR (for Alternate Pocket)

(1) Alternate Pocket Lining - 12" wide x 12" tall

(2) Alternate Pocket Flap Lining (use pattern piece)

(1) Case Binder piece - 13.5" wide x 3" tall

(1) Loop - 5" wide x 1.25" tall or use elastic hair tie

From Vinyl:

(1) vinyl - 13.5" wide x 1.5" tall

(1) vinyl - 13.5" wide x 6.5" tall

From Fusible Woven Interfacing:

(2) Handles - 11" wide x 4" tall

(2) Alternate Pocket Flaps (use pattern piece)

From Cotton Canvas/Fusible Fleece:

(1) Exterior - 13.5" wide x 18" tall

From Cotton Batting:

(1) Exterior - 13.5" wide x 18" tall

* = After quilting a small amount of shrinkage is common and acceptable, if you feel that your chosen quilting design/fabrics will shrink the exterior more than 1/4" when quilted, please cut this piece larger accordingly and trim to size after quilting.

Suggested Cutting Layout:

◐ = wrong side ◑ = right side

+ Measurements require full FQs using these layouts.

Exterior Fabric:

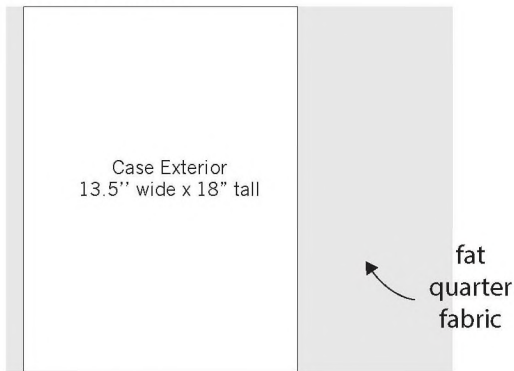

Cotton Canvas/Fusable Fleece:

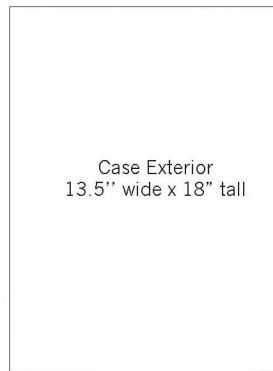

16 gauge Clear Vinyl:



Lining Fabric:

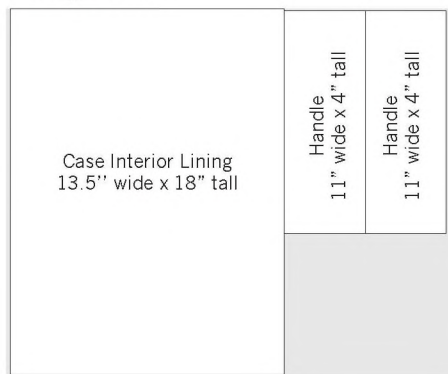

Cotton Batting:

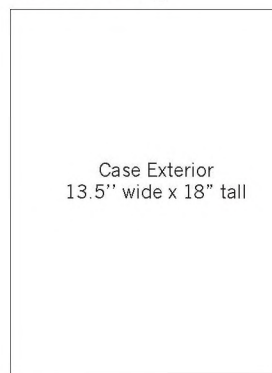

Long Pocket:

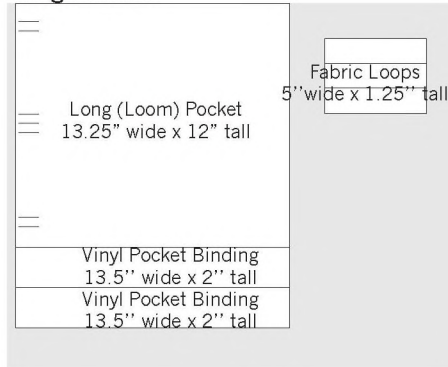

Alternate Pocket:

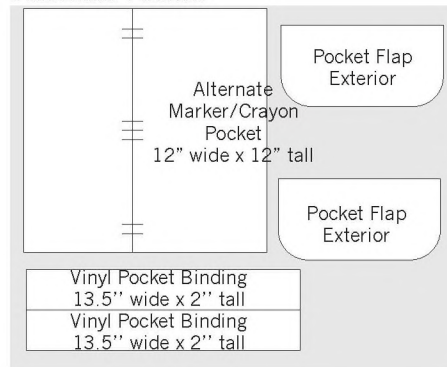

OR

Long Pocket Lining:



Alternate Pocket Lining:

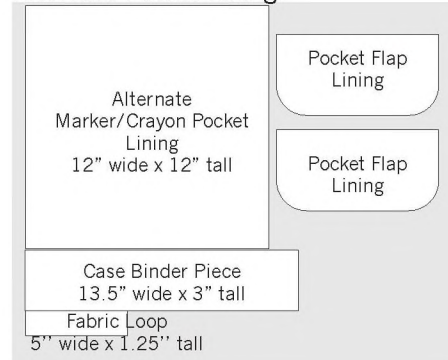

Sewing Instructions:

RST = Right Sides Together WST = Wrong Sides Together

● = wrong side ○ = right side

{1/2" seam allowances used throughout unless otherwise noted}

PREPARE: FUSE INTERFACING

Before beginning, fuse interfacing to handle and flap (if using alternate pockets) pieces as directed by manufacturer.

STEP 1: QUILT EXTERIOR/LINING

a) Layer batting with exterior fabric centered right side up on top. Smooth fabrics, pin or spray baste layers together and quilt (walking foot is helpful for straight line quilting). Set aside. Next, layer canvas then lining piece right side up on top. Baste pieces together along edges or quilt. Set both pieces aside.

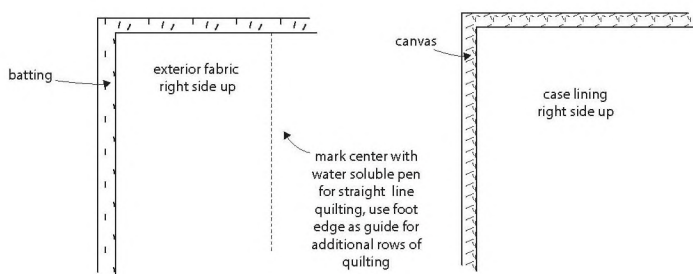

STEP 2: MAKE VINYL POCKET

a) Press pocket binding strips in half WST, open, press raw edges to center, press in half again. Open up binding and slip over long edge of vinyl. Stitch in place close to edge of fabric. Repeat for remaining binding strip and vinyl piece.

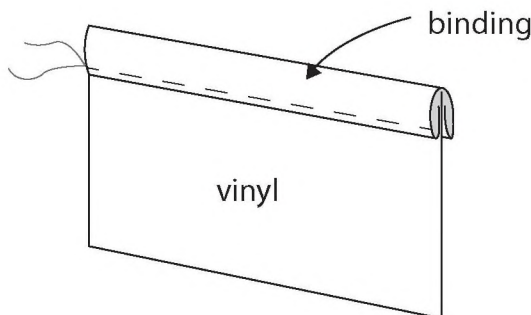

TIP: When sewing the vinyl sometimes the presser foot gets 'stuck' to the vinyl, if you're having this problem, try putting a layer of tissue paper over the vinyl (torn away after stitching), or use a piece of scotch tape on the bottom of your presser foot. Or use a teflon foot.

b) Carefully pin binding onto each side of zipper about 1/4" away from zipper teeth (being sure to pin through the vinyl that will be covered up by the binding) or use 1/4" fusible tape to temporarily hold in place. Sew close to folded inner edge of binding. Slide zipper open/closed to make sewing easier. Repeat for remaining side. Set assembled vinyl pocket aside.

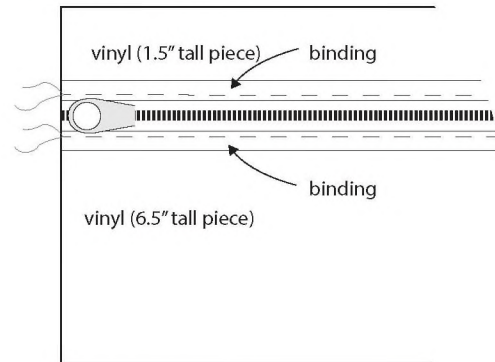

STEP 3: MAKE POCKETS

For alternate pocket instructions skip to next page.

a) For long pockets: Place long pocket pieces RST. Sew along short edge.

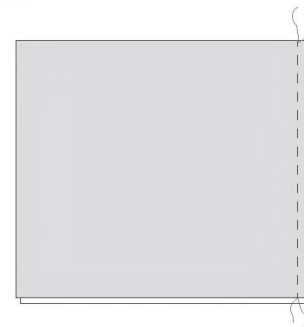

b) Flip so wrong sides are facing. Press. Sew 1/2" from edge to create elastic casing. With a water soluble pen mark a straight line dividing the pocket horizontally in two, 6" up from the bottom edge. Using a safety pin or bodkin, thread 1/4" elastic through casing.

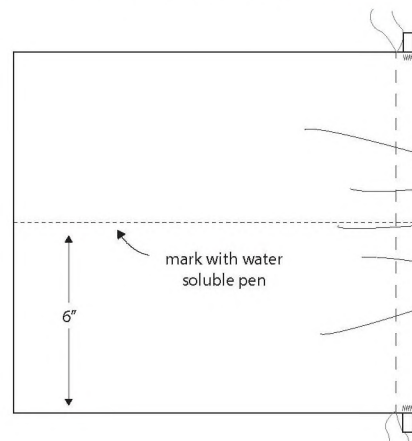

Secure elastic at one end with a zig zag stitch then tightening the elastic so the pocket measures about 10" wide and securing elastic to remaining side with a zig zag stitch. Trim any excess elastic from edges.

c) Make pleats. Using pleat markings from pleat pattern template, fold pleat lines so that they are right sides facing. Secure pleats in place by pinning.
 + Overall height of pocket after pleating should measure approx. 8" tall.

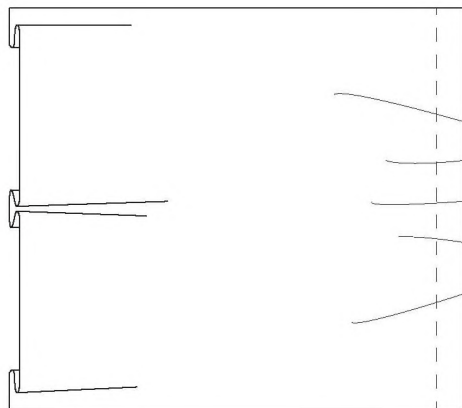

With water soluble pen, mark a horizontal line on interior lining piece 8" up from bottom of case. Lay pleated pocket right side up on top of right side of lining piece. Pin in place aligning raw edges to bottom, marked line and left side. Baste along bottom edge and long sides of pocket.

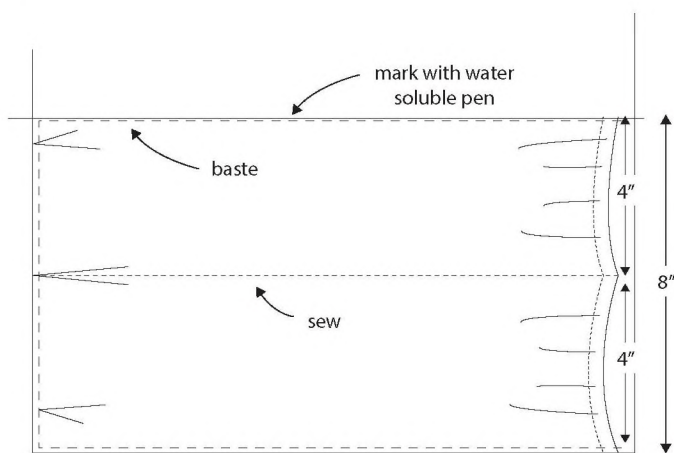

d) Divide pocket. Sew along marked line (from step 3b) being sure to backstitch at the top of the pocket opening.

+ The next steps are instructions for the alternate flap pocket version. Skip to Step 4 if not using alternate version.

Alternate a) With water soluble pen, mark a horizontal line on interior lining piece 8" up from bottom of case. Set aside.

Alternate b) Place alternate pocket pieces RST, sew along opposite edges (leave other two edges unsewn). Turn right side out and press. Topstitch. With a water soluble pen mark a vertical line 4" from left finished pocket edge. Mark another line horizontally 6" from the top raw edge (see top diagram in right column).

Alternate c) Sew on hook side of hook & loop tape pieces as indicated on diagram below.

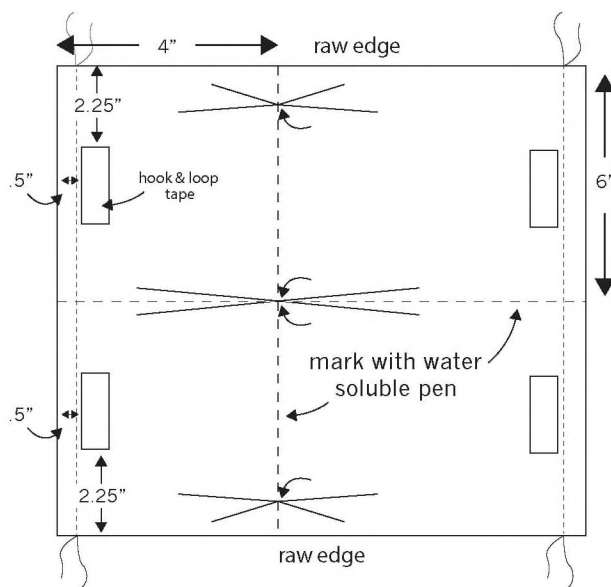

Alternate d) Make pleats. Using pleat marking template mark pleats on vertical line. Fold pleat lines so they are right sides facing. Pin. Secure pleats in place by pinning pocket (centered with bottom raw edge aligned to bottom of case - and top raw edge aligned to the horizontal mark you marked in alternate a) onto lining piece. Sew along vertical line (marked in alternate b) through all pleats, creating a pocket that is divided down the center. Baste pocket to lining piece along raw edges of pocket as well.

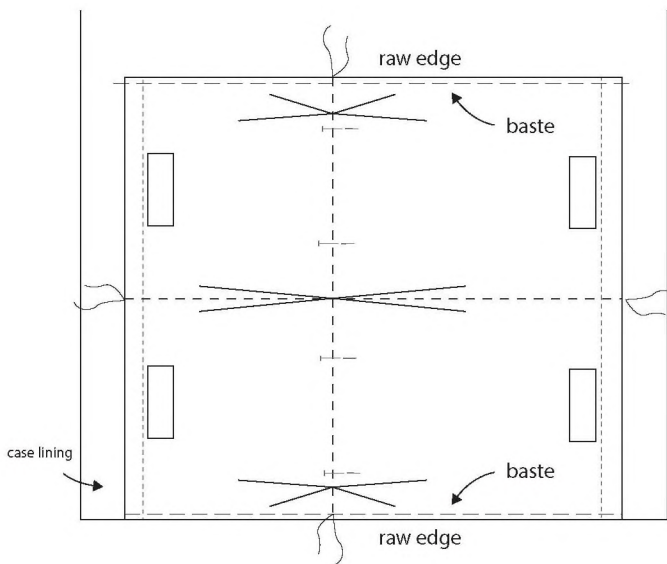

Alternate e) Divide pocket again by sewing across the horizontal line you marked in alternate b). Sew, being sure to backstitch at the edge of each pocket opening.

Alternate f) Make pocket flap. On the right side of pocket flap lining sew 2 pieces of loop side of hook & loop tape as indicated on pattern piece. Repeat for remaining pocket flap.

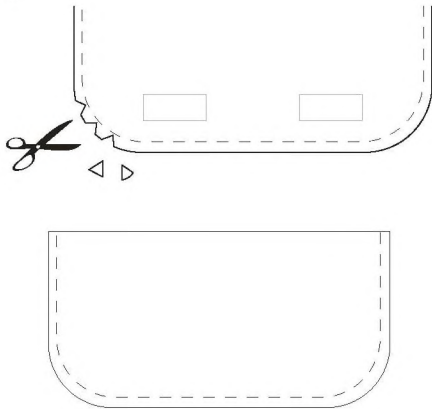

+ Be sure to fuse interfacing to wrong side of both pocket flap lining pieces if you haven't already.

Alternate g) Place one pocket flap exterior and one pocket flap lining RST. Sew along side and bottom edge, leaving top open. Clip curves. Turn right side out. Press. Topstitch along pocket flap edge. Repeat for remaining pocket flap. Set aside.

STEP 4: MAKE HANDLES/LOOPS

Both the handles and button loops are assembled in a similar way. As an alternative to creating button loops elastic hair ties work as well, simply cut elastic hair ties in one place and fold in half to create loop.

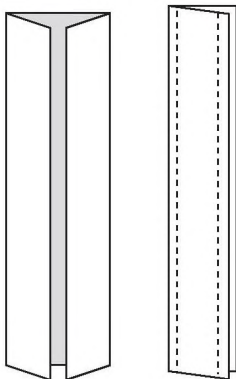

+ Be sure to fuse interfacing to wrong side of both handle pieces if you haven't already.

a) Make handles: Press handle in half WST, open, press raw edges to center, press in half again. Topstitch along both handle edges. Add additional rows of topstitching as desired. Repeat for remaining handle.

b) Make loops: Press loop piece in half WST, open, press raw edges to center, press in half again. Topstitch along long loop edge. Repeat for remaining two loops.

STEP 5: ASSEMBLE

a) Place vinyl pocket on top of lining piece, baste in place along zipper edges, use binder clips to temporarily hold in place. Baste loop of 1" wide elastic in place approximately 1.5" from top basted edge of pockets.

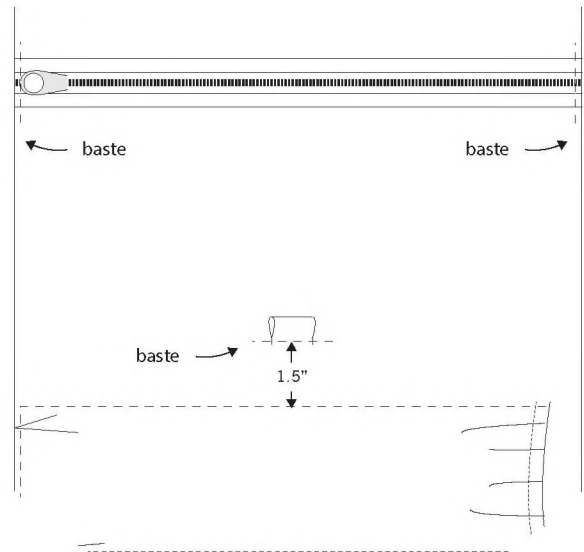

b) Press case binder piece WST by 1/2" on both long edges.



c) For alternate pocket version: Baste pocket flaps in place on each side.

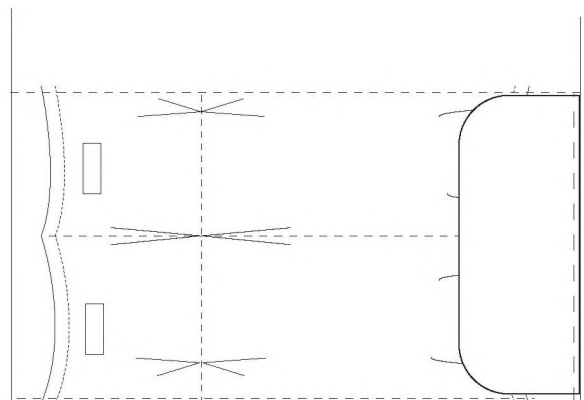

d) Lay case binder piece Right side up on top of vinyl pocket and long/flap pocket edges, covering the raw edges. Pin in place. Sew along both long edges of case binder piece. Baste long pocket loops in place as indicated below.

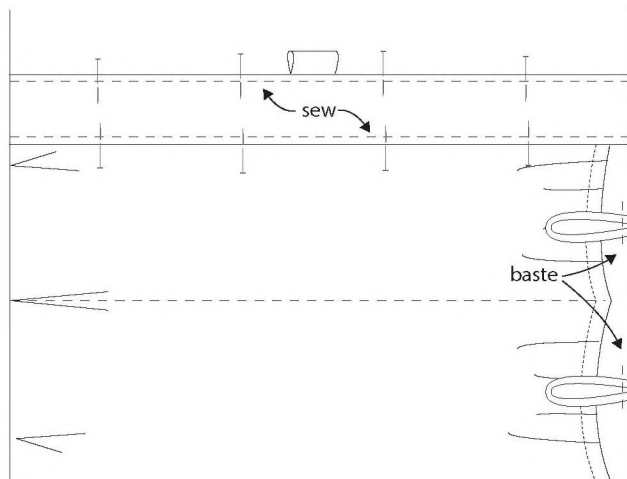

e) Baste handles and loop closure (or elastic hair tie) in place. Baste handles in place on each short edge of case, place handle edges 3" apart on center, being careful not to twist the handle. Baste loop in place as indicated on diagram.

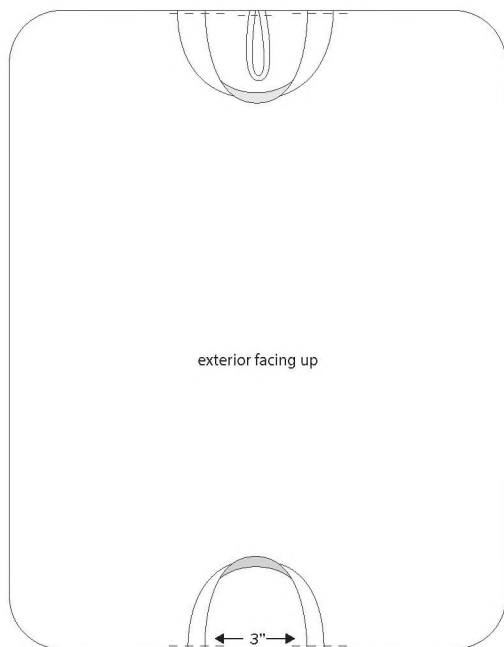

TIP: Keep handles and loop closures folded back towards exterior when applying bias binding.

STEP 5: BIND & FINISH

a) Round corners. Using rounded corner template, round all four corners of quilted case exterior and assembled lining piece. Mark corner with water soluble pen and trim away excess with rotary cutter or scissors. It is okay that a small amount of the pocket flaps/pocket will be trimmed off in the process of rounding the corners.

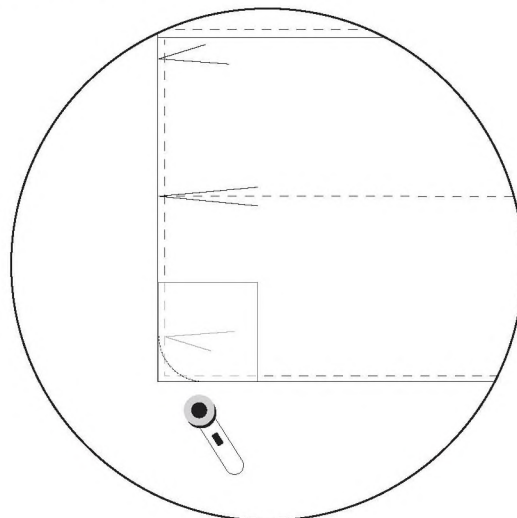

b) Place exterior quilted piece and assembled lining piece WST. Baste together with a 1/4" seam allowance along all edges. (Optional) You may also add additional rows of stitching across the binder piece through all layers for extra stability.

c) Attach bias binding. Unfold binding and align raw edge with raw edge of case right side of binding facing right side of lining. Fold over short end of binding WST by 1/2". Sew along all edges of case by sewing along the first crease of bias binding.

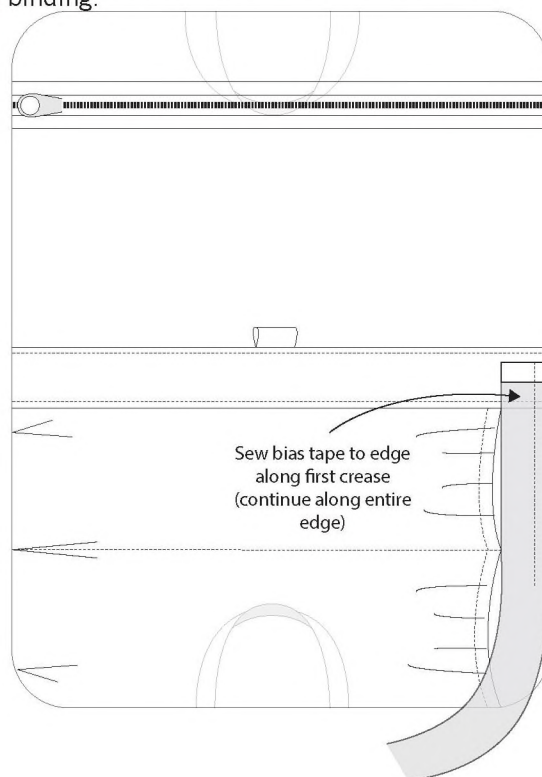

To help ease the bias binding around the curves clip into bias binding (by about a 1/4") as you reach each corner.

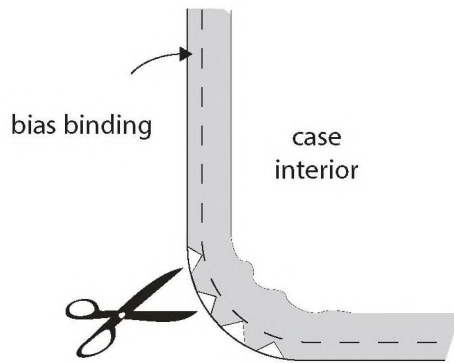

Overlap bias binding when you reach where you began. **Temporarily pin or move pockets/pocket flaps out of the way so they don't get unnecessarily caught in the binding.** Wrap bias binding around raw edge of case towards the case exterior. It helps to press the binding at this point, just be careful not to melt the vinyl pocket! Exterior side up, machine or hand stitch bias binding in place. Tip: Use 1/4" fusible hem tape to temporarily hold binding in place. Optional: Fold handles away from case and zig zag stitch in place along binding.

d) Sew on buttons (to long pockets and case exterior).

You're finished, enjoy your new case!

Share your tote on social media!
#RoadTripCase #NoodleheadPatterns



1 inch test square

When printed at 100% this box will measure 1" square

Tape pattern pieces together before cutting fabric: A to A and B to B

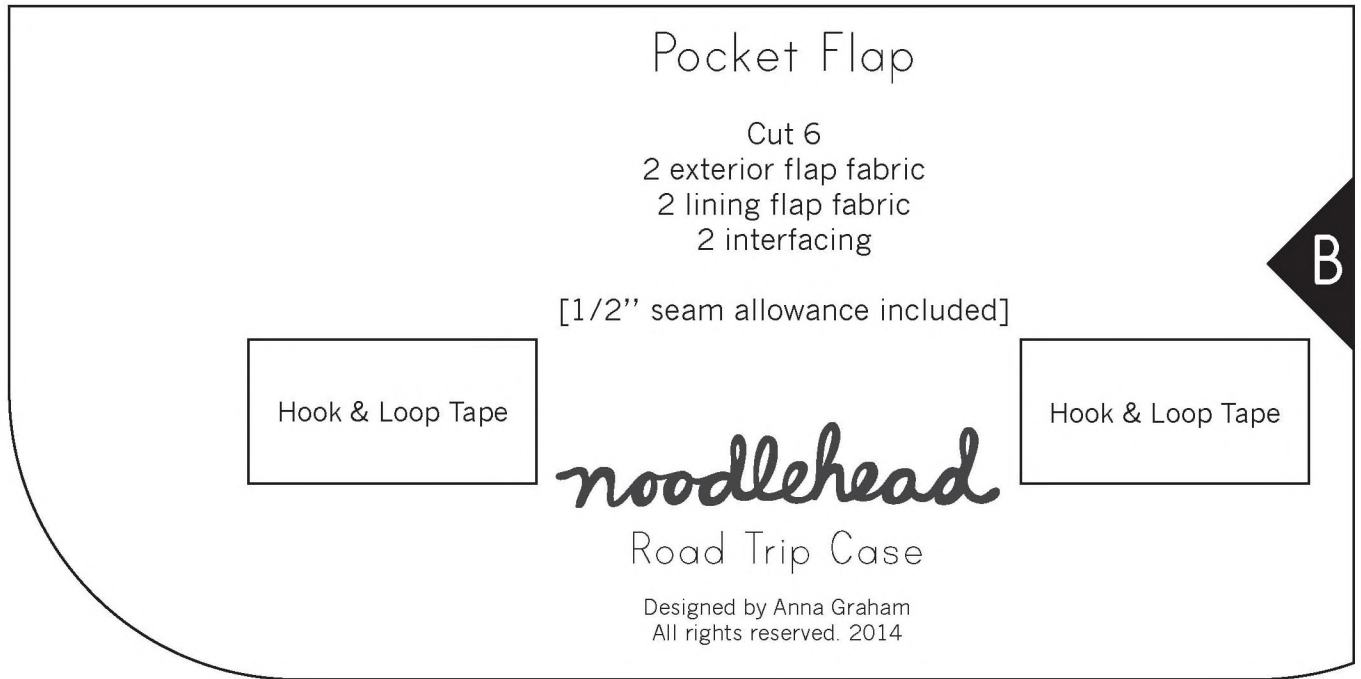

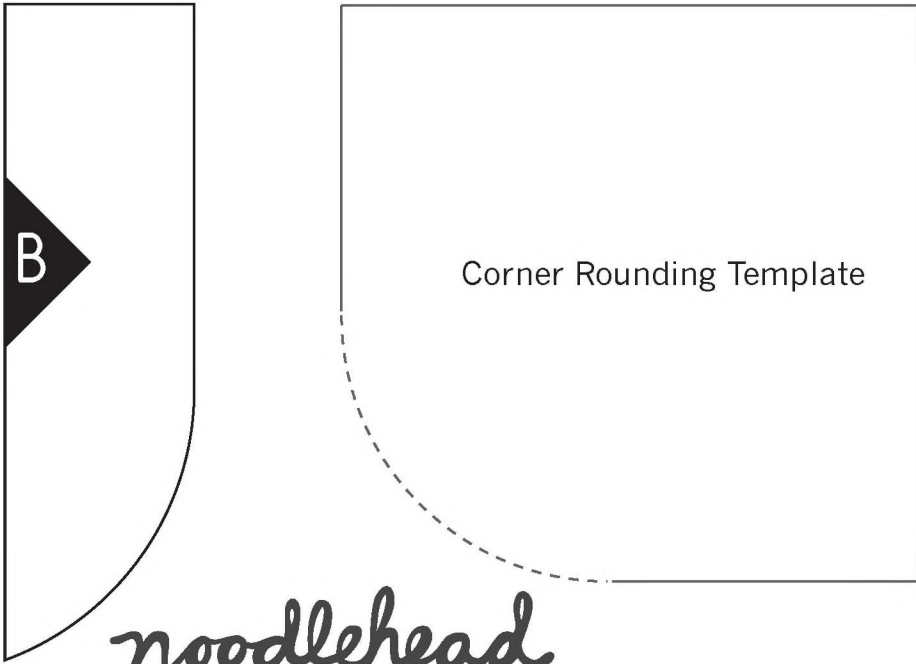

noodlehead

Road Trip Case

Designed by Anna Graham
All rights reserved. 2014

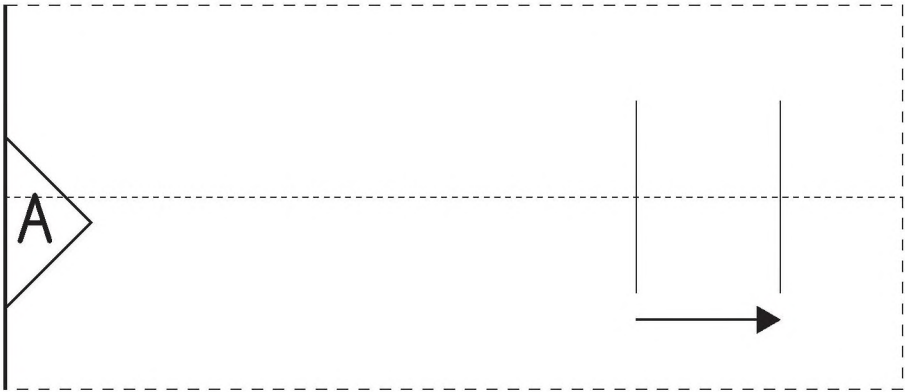

SUPER TOTE



noodlehead

extra roomy tote // front pocket // recessed zipper // interior pockets

Super Tote

A generous size tote bag with great features:

- Recessed zipper
- Large interior elasticized pockets
- Front pocket
- Fun piping and pleat details!
- Makes a great diaper or beach bag

Finished Dimensions:

15" wide, 15" tall, 3.5" to 5" deep, 10.5" handle drop

Supplies:

+ Requirements based on 44"-wide fabric.

Exterior and Front Pocket	1/2 yard
Lining (1 1/2 yards if lining front pocket)	1 yard
Straps	(2) 1/4 yard
Gusset (includes interior pocket pieces)	2/3 yard
Fusible Woven Interfacing (Pellon SF101 - 20"-wide)	2 1/4 yards
Medium Weight Fusible Interfacing (Pellon Craft-Fuse 808 or 809) or Cotton Canvas/ByAnnie's Soft and Stable	1 yard
1/4" wide elastic	1 yard
1/2" wide piping	15"
18" Zipper	
14mm magnetic snap (or 2" of 3/4" wide hook-and-loop tape)	
Additional supplies + tools: Thread, water-soluble pen, cutting mat, ruler, rotary cutter, walking foot (optional), denim needle	
Suggested Fabrics: home dec, heavy linen, denim, canvas, twill for exterior, quilting cottons for lining	

+ Please read through all instructions before beginning.

Zipper and Magnetic Snap sources:

SewingSupplies on etsy.com

BeingBags on etsy.com

Zipit on etsy.com

Cover tote fabric by Melody Miller, page 2 tote fabric by Rashida Coleman-Hale.

Pattern Information:

- 1/2" seam allowance throughout, unless otherwise noted
- 1/4" seam allowance for basting
- Make sure to backstitch at beginning and end of each seam to secure stitches
- Topstitch 1/8" away from edges or seams
- Use a longer stitch length when topstitching (3.0mm) for even and smooth stitches
- To find center, finger-press in half and mark within seam allowance

Sell finished sewn items: You (the purchaser) can sell finished Super Totes. Includes home-based production scale only. No commercial production allowed.

Pattern may NOT be reproduced, shared or redistributed.



Cutting Instructions: *See suggested cutting layouts below.

Assemble Pattern Pieces:

Print pattern pieces on your home printer. Be sure that your printer is NOT set to 'fit to page' when printing. Cut along solid lines, tape together at marked letters, matching 'A' to 'A' respectively and so on.

+ Seam allowances are included in all pattern pieces.

From Exterior Fabric:
 (2) Exterior A
 (2) Exterior B
 (1) Front Pocket - cut 2 to fully line front pocket (skip pocket facing), additional fabric required

From Lining Fabric:
 (2) Lining A
 (2) Lining B
 (2) Gusset
 (2) Recessed Zipper Pieces
 (2) Zipper End Tab
 (1) Front Pocket Facing (optional)

From Gusset Fabric:
 (2) Gusset
 (2) Interior Pocket

From Strap Fabric (two each from 1/4 yard cuts):
 (4) Strap

From Fusible Woven Interfacing:
 (2) Exterior A
 (2) Exterior B
 (4) Gusset*
 (2) Strap

From Pellon Craft Fuse 808/809 or Canvas or Soft and Stable:
 (2) Exterior A
 (2) Exterior B

Elastic:
 (2) 14 1/2" lengths

*will be using double layer - use single layer if using heavier fabrics

Suggested Cutting Layouts:

● = wrong side ○ = right side

+ Based on 44"-wide fabric.
 + These are cutting suggestions, change to suit your needs as desired.

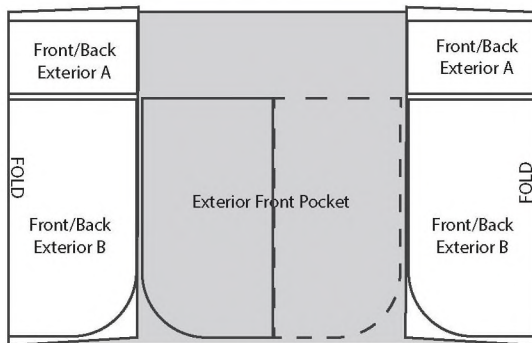

*This is a tight cut, please cut as accurately as possible.

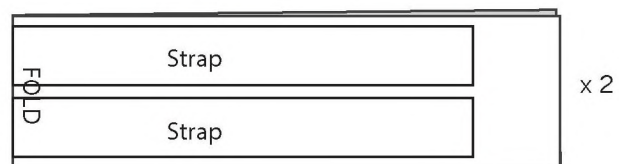
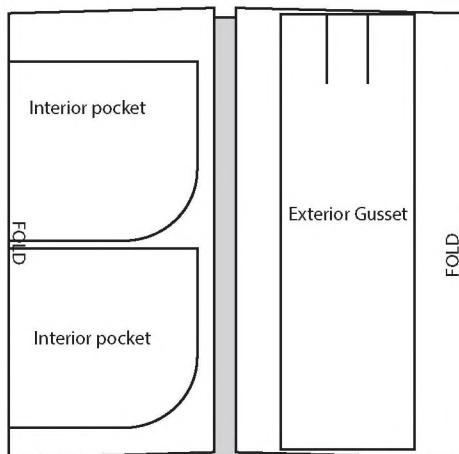
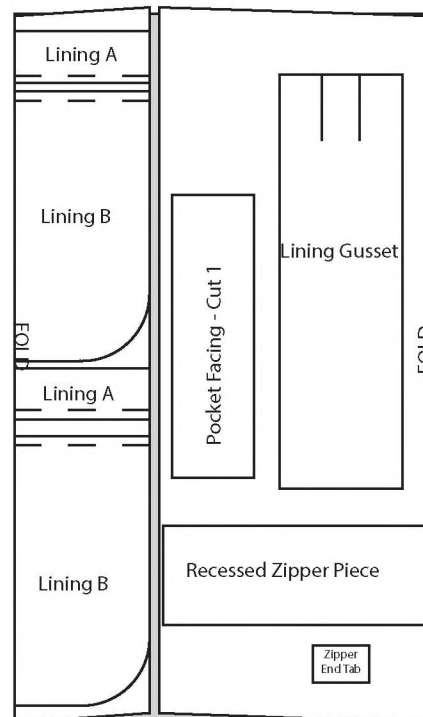

{1/2" seam allowances used throughout unless otherwise noted}

Prepare: Transfer Markings and Fuse Interfacing

- Transfer all markings to pattern pieces.
- Fuse woven interfacing to all exterior pieces: Exterior A/Exterior B, (Exterior Front Pocket if fully lining front pocket), Gusset, and exterior Strap pieces.
- Fuse Pellon 808/809 on top of fusible woven interfacing (or baste canvas/Soft and Stable using a 1/4" seam allowance) on wrong side of both Exterior A/Exterior B pieces.

For helpful tips for **installing a magnetic snap** or **making handmade piping**, please check out my free tutorials on my website www.noodle-head.com.

Step 1: Make Straps

a) Take two strap pieces (one lining fabric, one exterior fabric), right sides facing, sew along both long edges. Trim seam allowances to 1/4". Turn right side out using a safety pin. Press. Topstitch along either side 1/4" from edge then again 3/8" away. Repeat for remaining strap. *There are many ways to make a strap, this is my preferred method for accuracy. However feel free to use a method you like best!

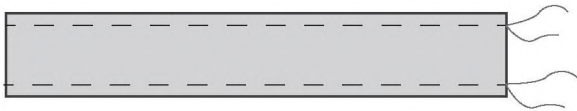

Optional: Take one strap, mark with a pin 12" from each raw end. Fold in half lengthwise so that lining sides are touching. Sew along the open edge between pins. Repeat for other strap.

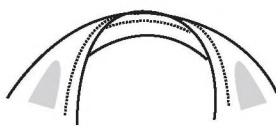

Step 2: Sew Exterior

a) Take Exterior Front B and align strap (right sides facing) along top raw edge. Space strap 4.5" apart - centered on exterior, pin in place.

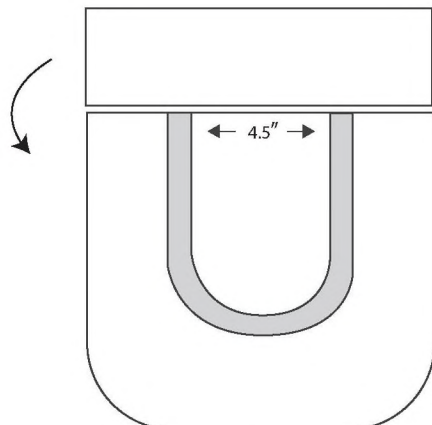

b) Place Exterior Front A right side down on top of Exterior front B, aligning raw edge with top raw edges. Pin. Sew.

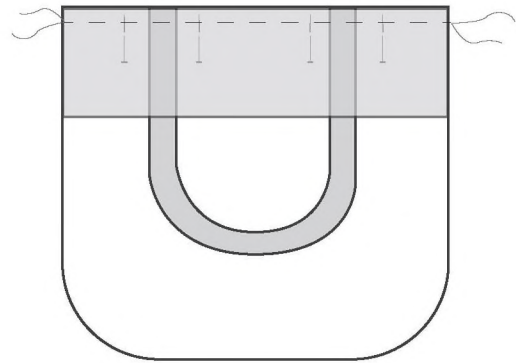

Press seam allowance down. Topstitch in place. Repeat for tote Exterior Back pieces A/B and remaining strap.

c) Sew as marked on diagram below for strap reinforcement, turning 1.5" below the top raw edge of the bag. Repeat for all straps.

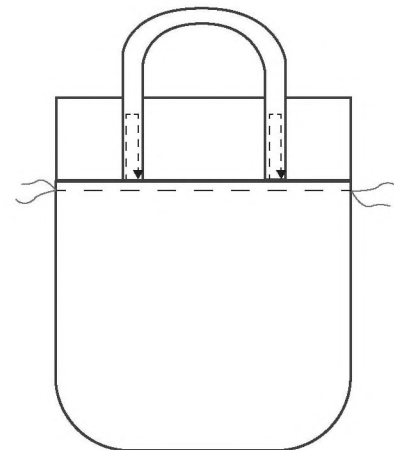

d) Make front pocket: Press pocket facing to wrong sides by 1/2" on both long edges.

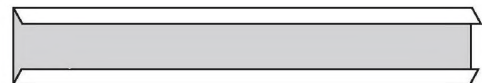

e) Baste piping in place aligning with top raw edge of front exterior pocket. Open up pocket facing along crease. Place front pocket piece and pocket facing right sides together (sandwiching piping in between.) Sew along pressed crease.

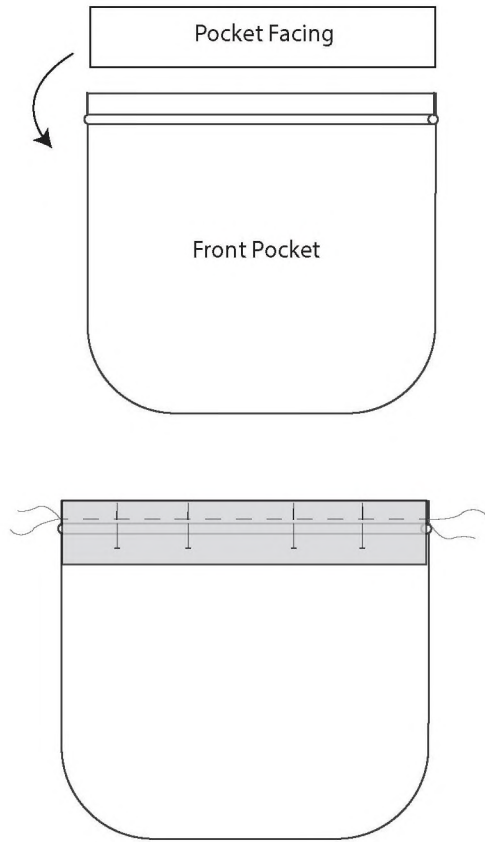

Optional: Insert lightweight magnetic snap or sew in a 2" strip of hook & loop tape along pocket facing before step f).

f) Flip so that wrong sides are facing, tucking under raw edge you pressed earlier. Sew along top edge of facing and bottom fold of facing. Press!

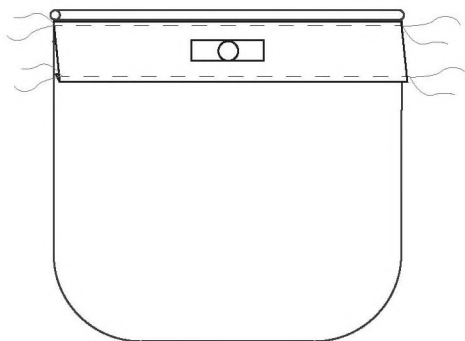

Optional: If desired, cut additional Front Exterior pocket piece to use as full lining (in place of the pocket facing piece). Sew pocket lining and pocket exterior right sides together at top edge and continue.

g) Place pocket on top of assembled front exterior piece, align to bottom edge and sides. The top of the pocket will just cover the seam where the straps are sewn. Baste in place along sides and bottom. This will be referred to as the assembled bag front.

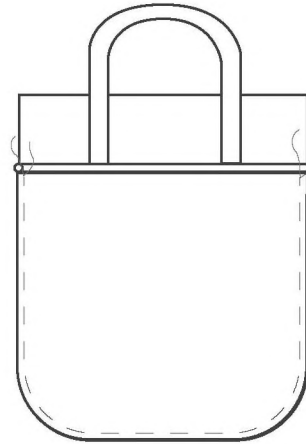

If you chose to add a magnetic snap or hook + loop tape, align pocket and mark where to insert snap or loop tape on assembled exterior and install.

Step 3: Sew Gusset

a) Take both exterior gusset pieces and place right sides facing. Sew along one short edge. Open up. Press to one side. Topstitch along the seam for reinforcement.



b) Sew gusset pleats: As indicated on pattern pieces fold right sides together so that the pleat markings are aligned.

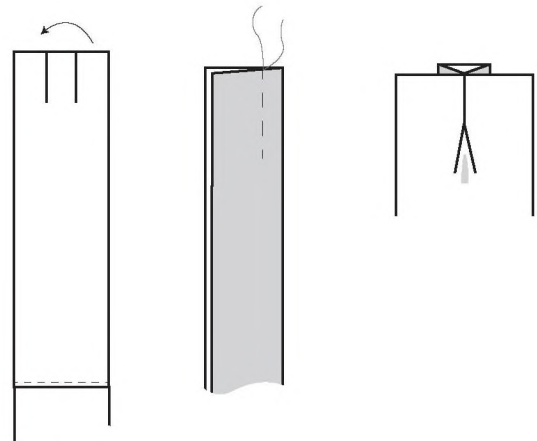

c) Sew along indicated length of pleat marking, being sure to backstitch several times. Press pleat open. Repeat for other gusset pleat. Set aside.

d) Attach gusset: Align center seam of gusset with bottom center of assembled bag front. Pin generously starting at top sides and working toward bottom center. Clip into seam allowance by 1/4" to ease the gusset around each corner. Sew starting at top edges and meeting in middle. Press seam allowance towards gusset and topstitch in place (optional).

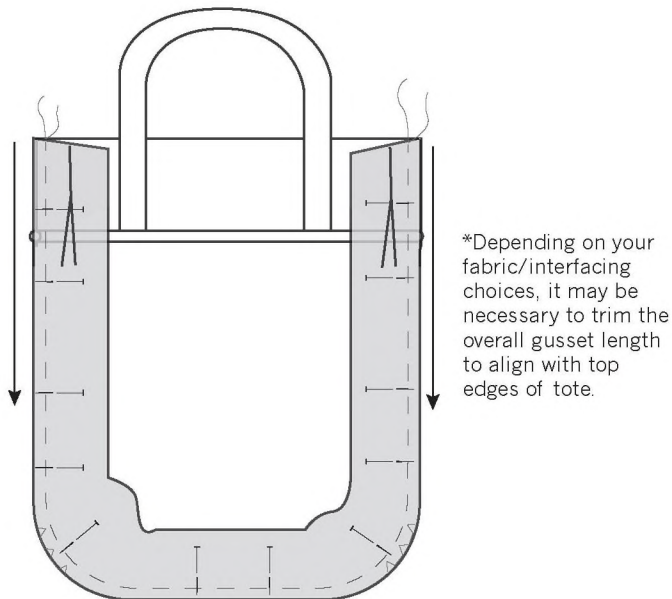

Repeat step d) to attach back side of tote to the gusset.

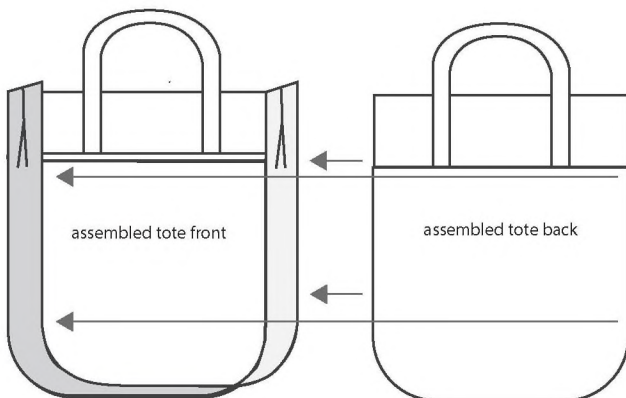

Turn right side out. Press well.

Step 4: Sew Recessed Zipper

**If you choose not to use a recessed zipper, simply cut the lining pattern pieces at the dotted lines and tape together. Cut 2 lining and skip to Step 5.

a) Press recessed zip pieces in on all sides by 1/4" starting at short ends, wrong sides touching. Press both pieces in half lengthwise.

b) Open up one Recessed Zipper piece and align long edge with underside (bottom) of zipper tape, centering on length of zipper, raw edge of fabric aligned with zipper tape. Pin. Sew. Flip recessed zipper piece so that it wraps around the zipper tape. Pin.

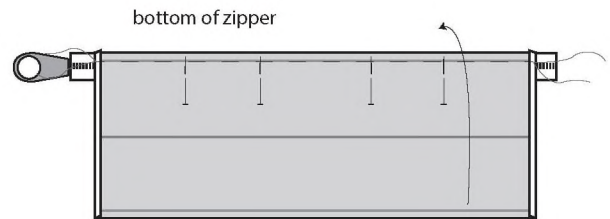

c) Topstitch along both sides and long edge next to zipper, leaving the folded edge unsewn (this edge will be sewn into the lining). Repeat steps b) and c) with other recessed zipper piece, sewing onto the opposite side of zipper. Press.

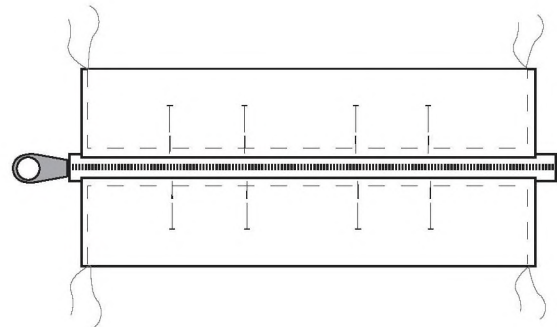

d) Attach zipper tabs to each end of zipper by folding in zipper end tab towards wrong side by 1/2" on each side, press in half again.

Slip zipper tab over zipper tape end, pin, topstitch around all edges of tab. Repeat for other zipper end.

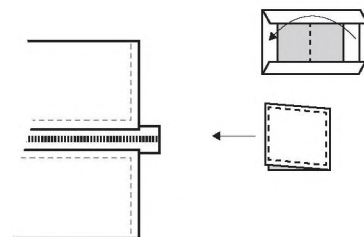

* If the width of your zipper (including zipper tape) is wider or narrower, adjust zipper end tab accordingly.

Step 5: Sew Lining

Make interior pockets:

a) Sew top elastic casing by pressing top edge of pocket toward wrong side by 1/4" and again by 1/2". Topstitch along bottom fold. Insert 14.5" of elastic by using a safety pin and insert through casing. Feed elastic through until approximately 1/4" remains on one side. Use a zig zag stitch and sew to hold the elastic in place. Stretch elastic through the casing until it comes out the other side. Zig zag stitch in place on edge, trim any remaining elastic.

b) Baste bottom of interior pocket. Gather until pocket measures approximately the width of Lining B piece.

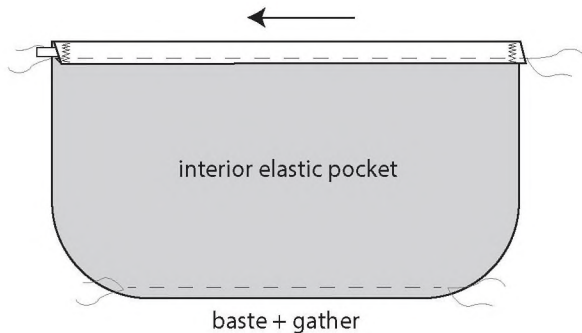

c) Place finished pocket on top of one Lining B piece. Align with bottom and side raw edges. Baste in place. Sew vertical rows of stitching to create divided sections as indicated on diagram. Repeat for other pocket and Lining B piece if desired.

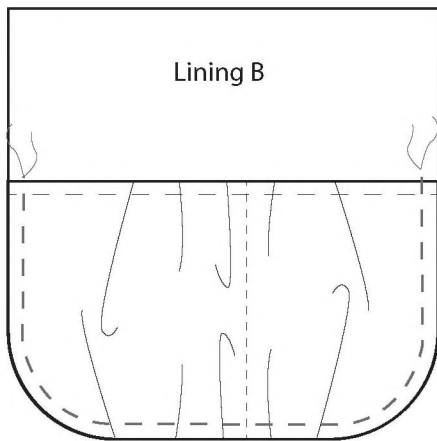

d) Take one Lining B, right side up. Place assembled zipper right side up, centered, aligning raw edge with folded edge of assembled recessed zipper pieces.

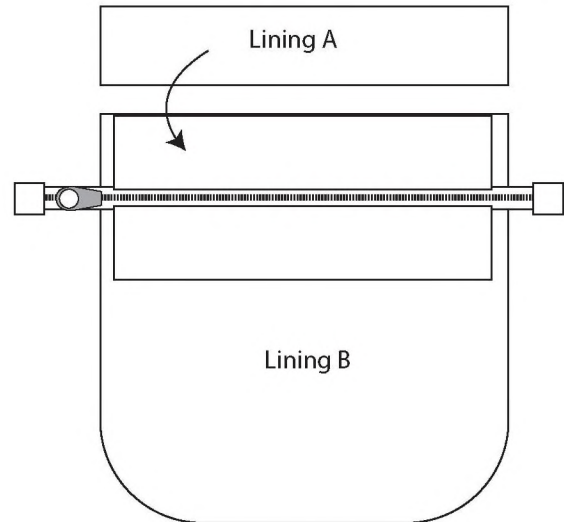

Place Lining A right side down on top of Lining B, aligning raw edges. Pin. Sew.

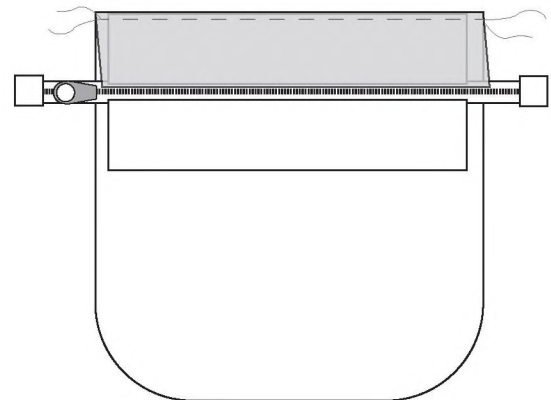

e) Press seam allowance upward. Topstitch along seam. Repeat for remaining lining A/B pieces, again inserting assembled zipper between and sewing.

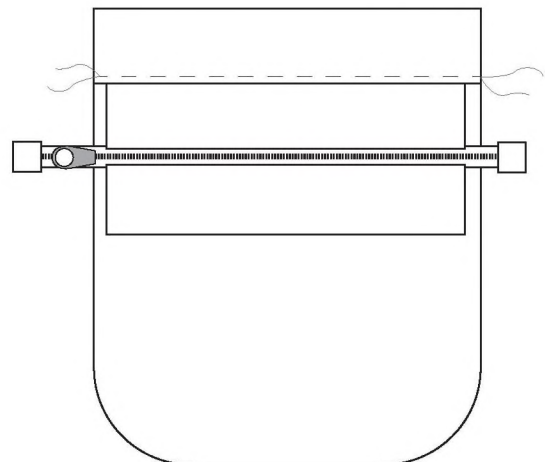

f) Make and attach lining gusset same as exterior gusset (following Step 3). Attach gusset to one side of lining as in Step 3d. Repeat for other side of lining, this time leaving a 4-5" opening in the bottom or side seam. Be sure to not accidentally sew any part of the recessed zipper into the side seams. Open zipper.

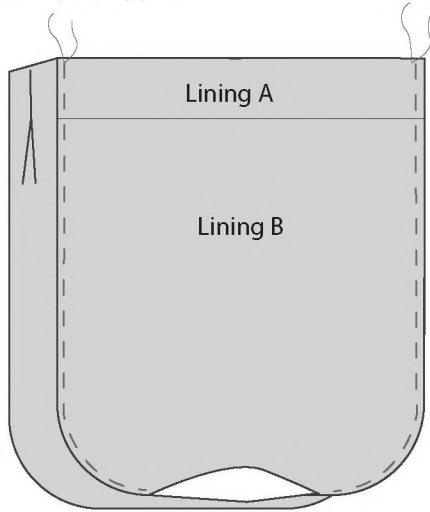

Step 6: Assemble Tote

a) Slide assembled exterior into assembled lining. Right sides facing. Pin along top opening. Zipper pull will be on the left if back of tote is facing you (for right handed people - opposite for left handers). Be sure to tuck straps and zipper end tabs down in between lining and exterior. Sew along top opening. Gently pull tote right side out through the opening that was left in the lining. Stitch lining opening closed, tucking in raw edges and sewing with a small seam allowance or by hand. Push lining into tote. Press well along top edge. Topstitch along top edge using a slightly longer stitch length. (See note in right column for additional reinforcement tips.)

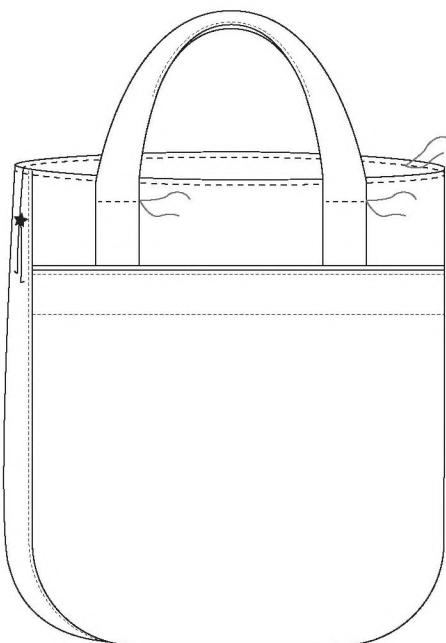

Share your tote on social media!
 #supertote
 or in the flickr group:
www.flickr.com/groups/noodleheadtutorials/

Optional: If the bag will be used for carrying heavy items, stitch through the exterior/strap/lining along horizontal line that was sewn earlier on the straps to reinforce handles.

Optional: Stitch a short horizontal line across bottom opening of each pleat through all layers (as indicated at left). This helps secure the lining as well as reinforcing the pleat.

Give your tote another overall press and you're done! Enjoy!

1 inch test
square

When printed at
100% this box will
measure 1" square

A

Front/Back Exterior B

Cut 6
2 exterior fabric
2 fusible woven interfacing
2 Craft Fuse/canvas/Soft and Stable

noodlehead

Super Tote Pattern

Designed by Anna Graham
All rights reserved. 2013

Front/Back Exterior A

Cut 6
2 exterior fabric
2 fusible woven interfacing
2 Craft Fuse/canvas/Soft and Stable



Front/Back Exterior B

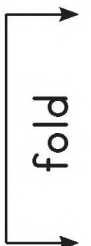

A



B

fold

Front Exterior Pocket

Cut 1
1 exterior fabric

* Cut 2 if you wish to fully line this pocket,
additional fabric may be required

noodlehead

Super Tote Pattern

Designed by Anna Graham
All rights reserved. 2013

Front Exterior Pocket



Zipper End Tab

Cut 2

[3" wide x 2" tall]

Lining A

Cut 2
2 lining fabric



[Cut at dotted line if not using recessed zipper.]

[Cut at dotted line and tape together with Lining A if not using recessed zipper.]

Lining B

Cut 2
2 lining fabric





noodlehead

Super Tote Pattern

Designed by Anna Graham
All rights reserved. 2013

Lining B

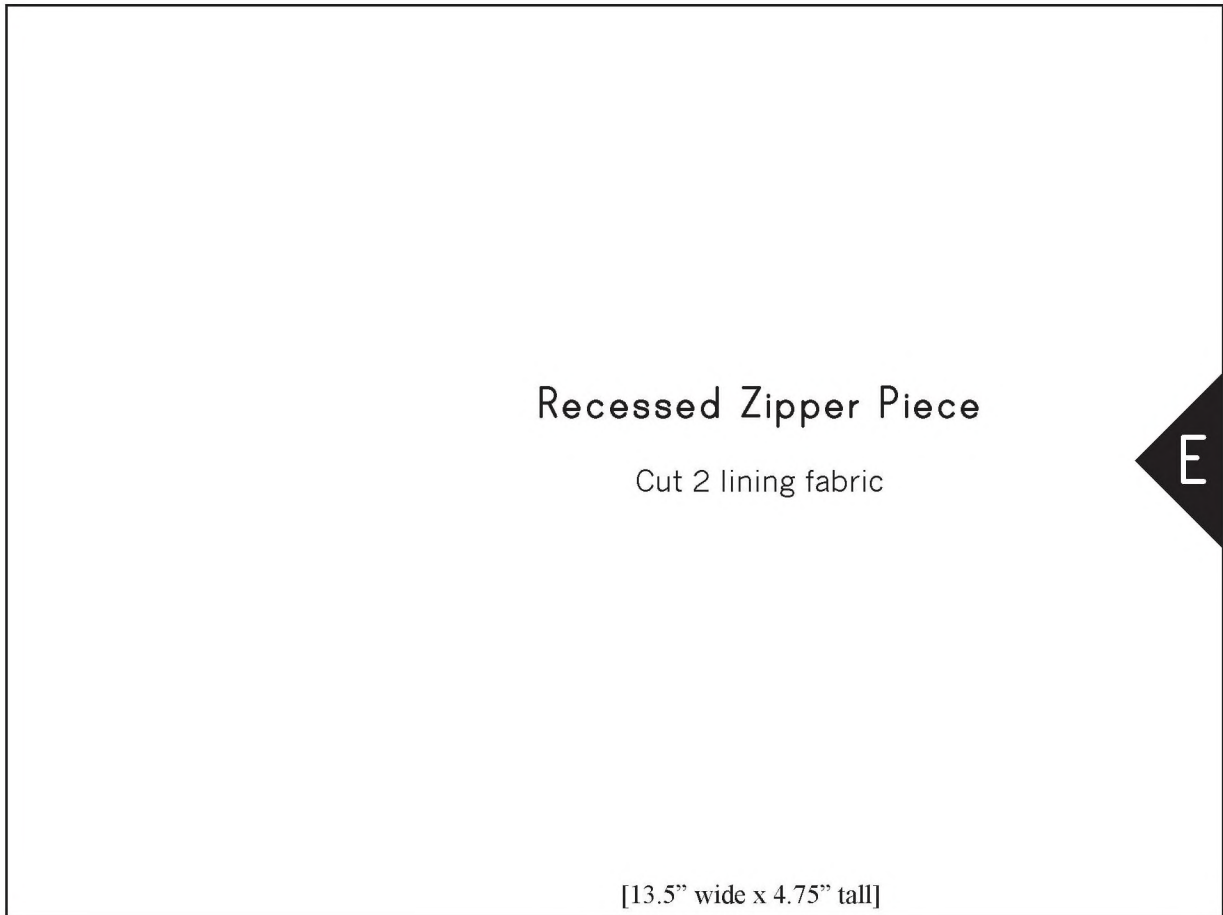
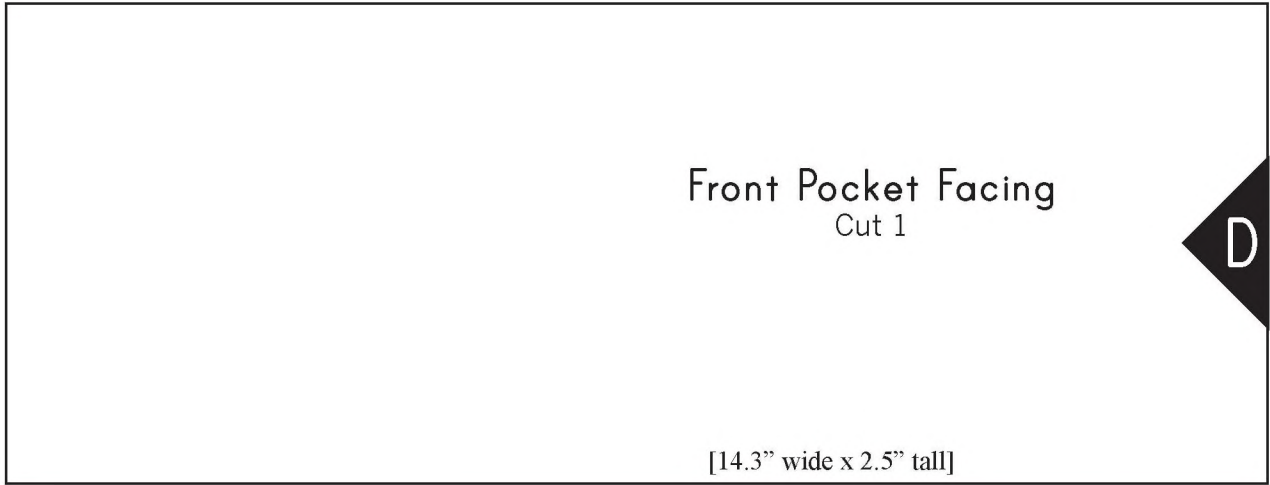

D

noodlehead

Front Pocket Facing

E

Recessed Zipper Piece

noodlehead

Super Tote Pattern

Designed by Anna Graham
All rights reserved. 2013

Interior Pocket

Cut 2

F

noodlehead

Super Tote Pattern

Designed by Anna Graham
All rights reserved. 2013

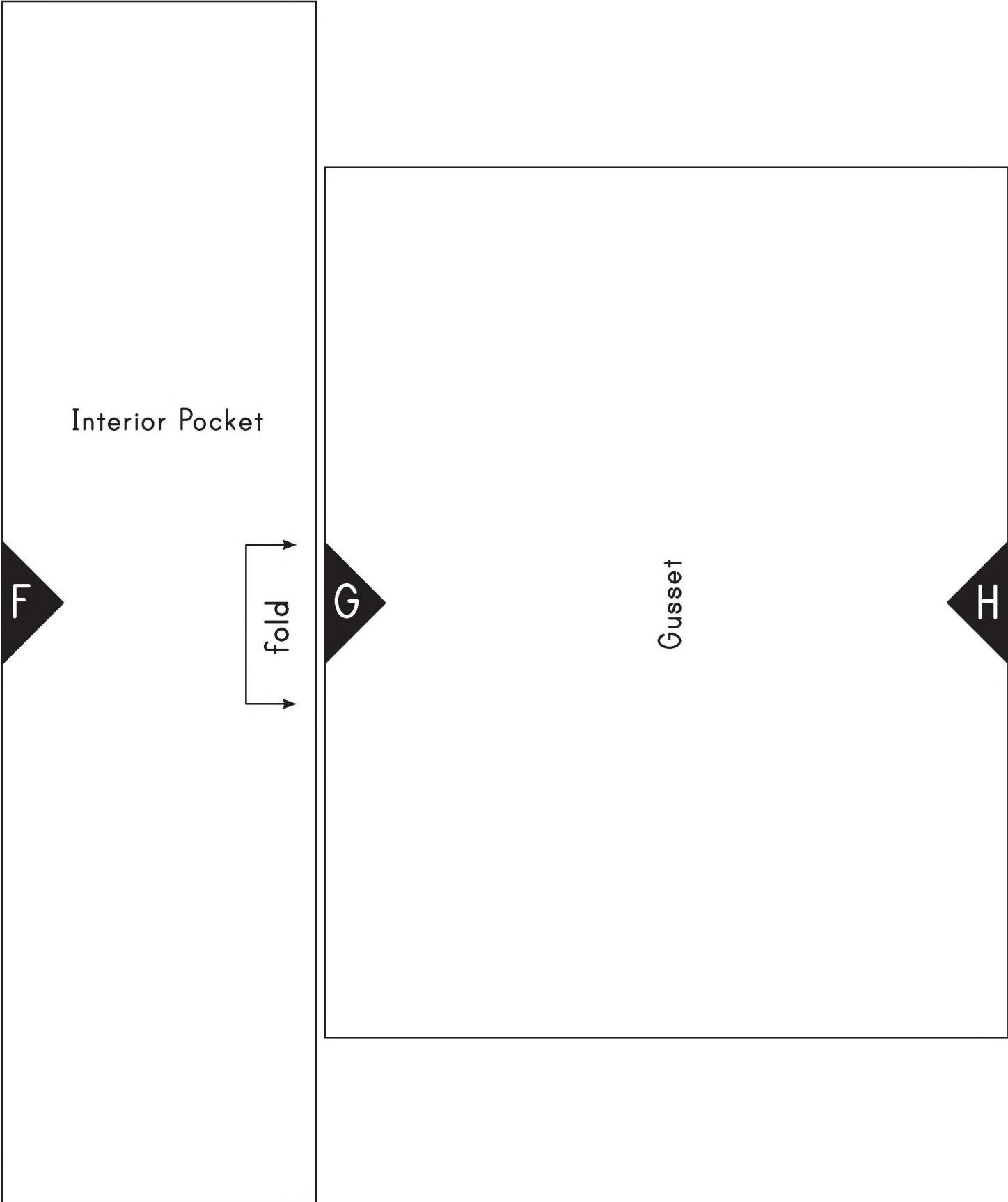

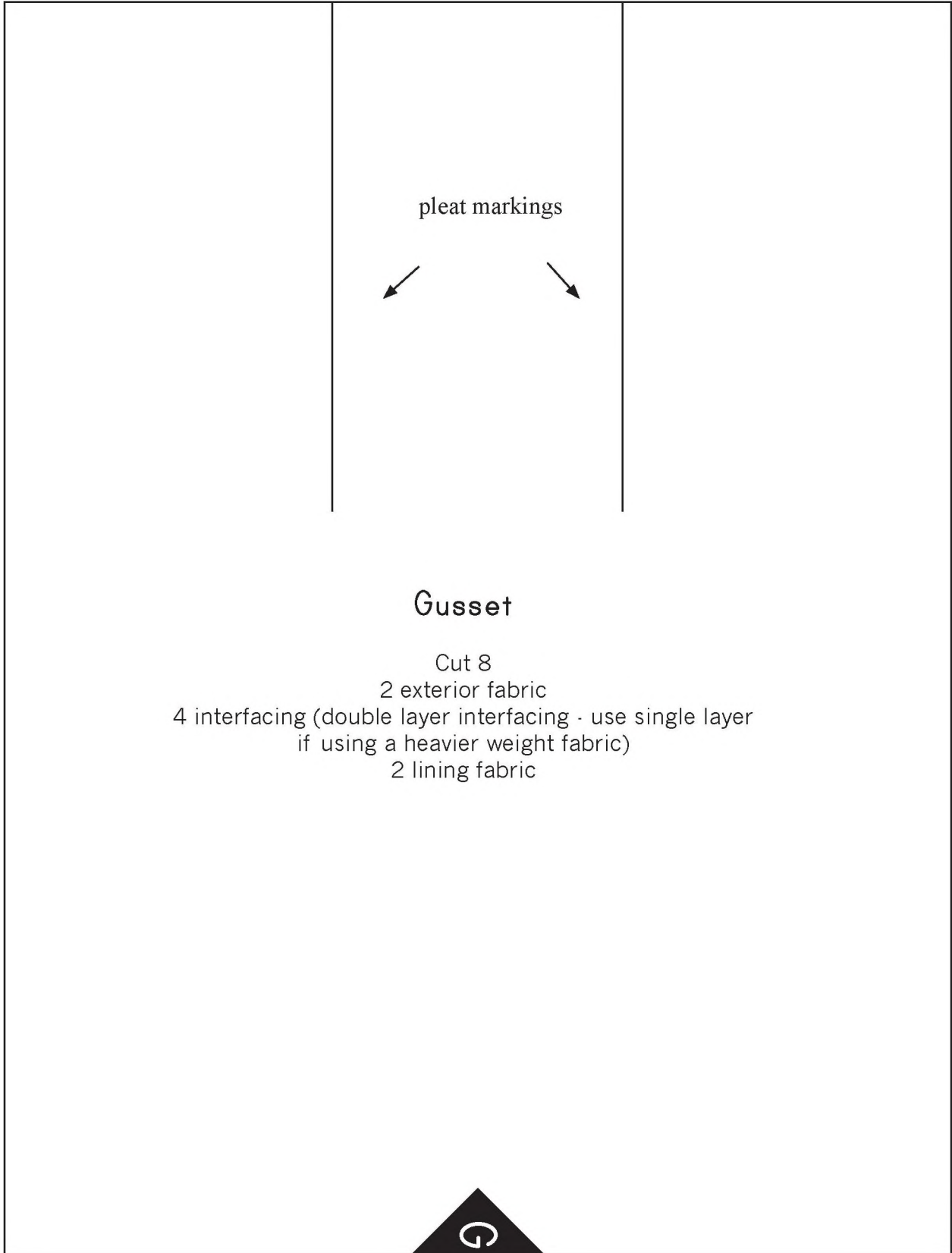

Strap
(pattern piece not
included, use ruler
and cutting mat)

2.75"W x 30" L

Cut 6
2 Fabric A
2 Fabric B
2 interfacing



H

Gusset

noodlehead

Super Tote Pattern

Designed by Anna Graham
All rights reserved. 2013